

predia

FLEX MOBILE



Predia Flex Mobile

The Predia Flex Mobile is an electrically height-adjustable lift solution on wheels, allowing you to position your touchscreen or display easily, quickly and safely at the desired height. Its robust mobile design makes it ideal for flexible use across multiple spaces.

🛡️ Safety first

The wide dual-column design ensures maximum stability, even with larger displays. The integrated dual anti-collision system prevents damage from obstacles and guarantees safe daily use. The Predia Flex Mobile complies with stringent safety standards such as CE, TÜV/GS and UL-EN-IEC 62368*.

📏 Flexible and mobile

Equipped with durable 100 mm castors, the system can be moved smoothly while remaining stable during use. Suitable for screens up to 98" (16:9) or 105" (21:9), with a maximum weight of 140 kg. The VESA range up to 800 x 600 ensures broad compatibility.

⭐ Easy to adjust

With an electric travel of 650 mm, the display can be adjusted precisely to the desired viewing height. Quiet, powerful motors ensure smooth and fast adjustment at the touch of a button.

↕ Accessories

Fully compatible with accessories such as a whiteboard frame, laptop shelf and keyboard tray. Ideal for classrooms, meeting rooms and training environments where flexibility is essential.

🔄 Durable design

The modular system is designed for long-term use and can easily adapt to changing requirements. High-quality materials ensure reliability and longevity.

Predia Flex Mobile

Model	OLS-MobileV3T1
Suitable for	Displays up to 98" (16:g) / 105" (21:g)
VESA range	800x600
Maximum load	140kg
Travel	650 mm
Speed	50 mm/s
Overload protection	Yes
Anti-collision	Dual anti-collision system
Soft start and stop	Yes
Caster size	100 mm (2 with brake, 2 without brake)
Power supply:	110-240V AC-50-60Hz
Socket	Yes, 3-way
Color	RAL 9005
Certifications	CE TÜV/GS* UL-EN-IEC 62368*
Warranty	5 years
Gross weight	49.5kg
Net weight	53kg
Whiteboard system available:	Yes (optional)
Keyboard tray available	Yes (optional)
Laptop shelf available	Yes (optional)

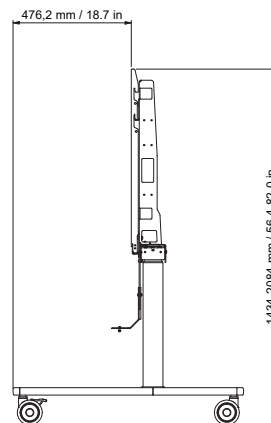
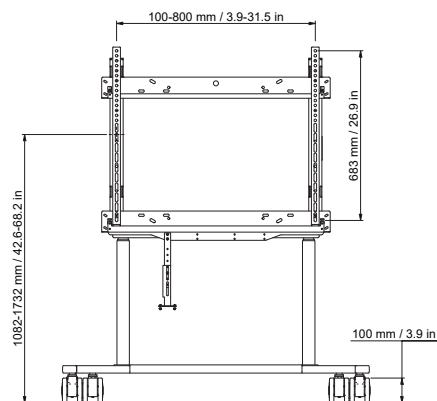
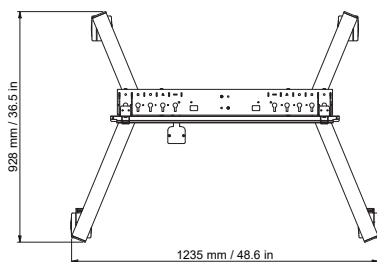

* Pending