



# User Manual

for S6 EO Series Off-grid Inverter



## Applicable models

S6-EO1P4K-48

S6-EO1P5K-48

S6-EO1P6K-48

## Applicable System

Single phase system

Ginlong Technologies Co., Ltd.

No. 57 Jintong Road, Binhai Industrial Park, Xiangshan, Ningbo,  
Zhejiang, 315712, P.R.China.

Tel: +86 (0)574 6578 1806

Email: info@ginlong.com

Web: www.solisinverters.com

Please adhere to the actual products in case of any discrepancies in this user manual.

## Smart O&M

In order to improve our products and provide you with higher quality services, this device has a built-in data logging module for collecting relevant information during operation (such as power generation data, fault data)

### **Commitment:**

1. We will only collect, use and process your device information for the purpose of improving our products and services.
2. We will take all reasonable and feasible measures to ensure that no irrelevant information is collected and we will protect your device information.
3. We will not share, transfer or disclose the collected device information with any company, organization or individual.
4. When we stop operating products or services, we will stop collecting your device information in a timely manner.
5. If you do not want to provide such information, you can notify our company to turn off this function, which will not affect your normal use of other functions of the product.

---

<b>1. Introduction</b>	2
1.1 Product Description	2
1.2 System Description	3
1.3 Packaging	3
<b>2. Safety &amp; Warning</b>	4
2.1 Safety	4
2.2 General Safety Instructions	4
2.3 Notice For Use	6
2.4 Notice for Disposal	6
<b>3. Installation</b>	7
3.1 Select a Location for the Inverter	7
3.2 Mounting the Inverter	8
3.3 Preparation	9
3.4 PV Input Terminal Assembly	10
3.5 Assembling the AC Connector	11
3.6 Grounding	13
3.7 Battery Terminal Components	14
3.8 Battery Communication	16
3.9 External Communication	17
3.10 Generator Connection	18
3.11 AC Coupling Connection	20
3.12 Parallel Connection	21
3.13 External Communication Stick Connection	23
3.14 LED Indicates	23
<b>4. Commissioning</b>	24
4.1 Preparation of Commissioning	24
4.2 Commissioning Procedure	24
<b>5. Operation</b>	25
5.1 Startup Guide	25
5.2 Main Menu	25
5.3 Information	25
5.4 Settings	30
5.5 Advanced Information	32
5.6 Advanced Settings	36
<b>6. Maintenance</b>	46
<b>7. Troubleshooting</b>	47
<b>8. Specifications</b>	53

# 1. Introduction

## 1.1 Product Description

Solis EO series inverter is designed for off-grid systems.

This series of inverters is highly flexible and can work with or without the grid to provide power to the load. It has battery connections for low voltage batteries and up to 2 PV string inputs. It is able to charge the batteries through the PV, grid or onsite generator.

This manual covers the EO series inverter model list listed below:

S6-EO1P4K-48, S6-EO1P5K-48, S6-EO1P6K-48

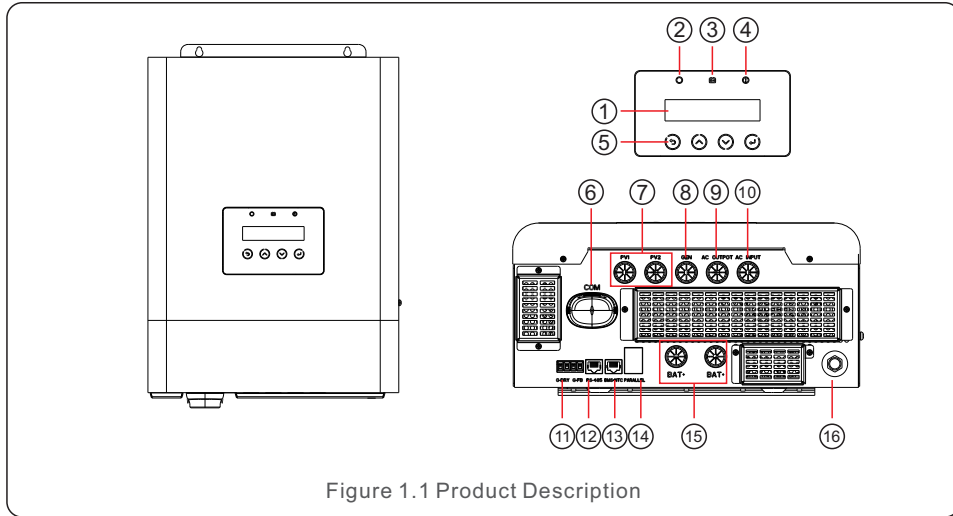

Figure 1.1 Product Description

NO.	Description	NO.	Description
1	LCD Display	9	AC Output
2	Status Indicator	10	AC Input
3	Battery Indicator	11	Generator start/stop signal
4	Fault Indicator	12	RS-485 Communicaton Port
5	Function Buttons	13	BMS/NTC Port
6	COM Port	14	Parallel Communication Ports
7	PV Input	15	Battery Connections
8	GEN Port	16	Circuit Breaker

Table 1.1 Product Description



**NOTE:**

Please refer to the specification of the battery before configuration.

# 1. Introduction

## 1.2 System Description

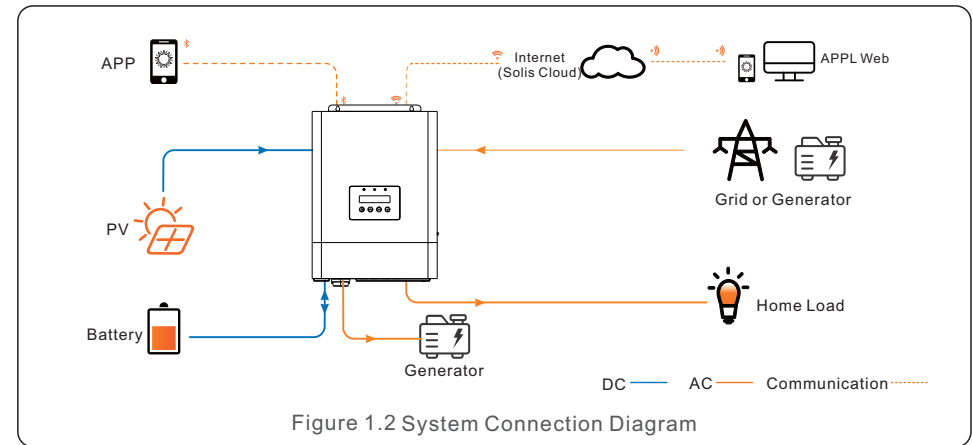
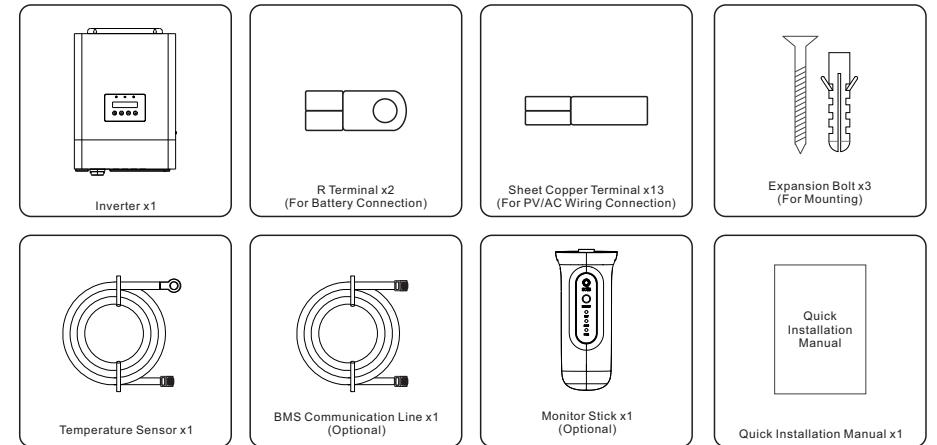

Figure 1.2 System Connection Diagram

## 1.3 Packaging

Please ensure that the following items are included in the packaging with your machine:



If anything is missing, please contact your local Solis distributor.

# 2. Safety & Warning

## 2.1 Safety

The following types of safety instructions and general information appear in this document as described below:



**DANGER:**

“Danger” indicates a hazardous situation which if not avoided, will result in death or serious injury.



**WARNING:**

“Warning” indicates a hazardous situation which if not avoided, could result in death or serious injury.



**CAUTION:**

“Caution” indicates a hazardous situation which if not avoided, could result in minor or moderate injury.



**NOTE:**

“Note” provides tips that are valuable for the optimal operation of your product.

## 2.2 General Safety Instructions



**WARNING:**

Only devices in compliance with SELV (EN 69050) may be connected to the RS485 and USB interfaces.



**WARNING:**

Please don't connect PV array positive (+) or negative (-) to ground, it could cause serious damage to the inverter.



**WARNING:**

Electrical installations must be done in accordance with the local and national electrical safety standards.



**WARNING:**

Do not touch any inner live parts until 5 minutes after disconnection from the utility grid and the PV input.

# 2. Safety & Warning



**WARNING:**

To reduce the risk of fire, over-current protective devices (OCPD) are required for circuits connected to the inverter. The DC OCPD shall be installed per local requirements. All photovoltaic source and output circuit conductors shall have isolators that comply with the NEC Article 690, Part II.



**CAUTION:**

Risk of electric shock, do not remove the upper cover ( lower cover can be removed for connection). There is no user serviceable parts inside, refer servicing to qualified and accredited service technicians.



**CAUTION:**

The PV array supplies a DC voltage when they are exposed to sunlight.



**CAUTION:**

Risk of electric shock from energy stored in capacitors of the Inverter, do not remove cover for 5 minutes after disconnecting all power sources (service technician only). Warranty may be voided if the cover is removed without authorization .



**CAUTION:**

The surface temperature of the inverter can reach up to 60°C (140 °F). To avoid risk of burns, do not touch the surface of the inverter while it's operating. Inverter must be installed out of the reach of children.



**NOTE:**

PV module used with inverter must have an IEC 61730 Class A rating.



**WARNING:**

Operations below must be accomplished by licensed technician or Solis authorized person.



**WARNING:**

Operator must put on the technicians' gloves during the whole process in case of any electrical hazards.



**WARNING:**

For PV system, between the PV string and PV input of the inverter, it is required to install a DC isolator to meet local installation regulations.

## 2. Safety & Warning



### WARNING:

Solis requires using two magneto-thermic automatic switches with an RCD module (with adequate voltage and current rating basing on the grid characteristics and on the output current of the inverter) with a sensitivity of 100mA, A-type. One switch with the RCD module needs to be installed on the AC input side, one RCD needs to be installed on the AC backup output side.

### 2.3 Notice For Use

The inverter has been constructed according to the applicable safety and technical guidelines. Use the inverter in installations that meet the following specifications ONLY:

1. Permanent installation is required.
2. The electrical installation must meet all the applicable regulations and standards.
3. The inverter must be installed according to the instructions stated in this manual.
4. The inverter must be installed according to the correct technical specifications.

### 2.4 Notice for Disposal

This product shall not be disposed of with household waste. They should be segregated and brought to an appropriate collection point to enable recycling and avoid potential impacts on the environment and human health. Local rules in waste management shall be respected .



## 3. Installation

### 3.1 Select a Location for the Inverter

To select a location for the inverter, the following criteria should be considered:

- Exposure to direct sunlight may cause the output power to decrease. It must install the inverter indoors and avoid direct sunlight and rain.
- This inverter is IP21 rated and it can be used indoors with environmental pollution level II. Please install it indoors to avoid rain, spraying water or splashing water.
- It is recommended that the inverter is installed in a cooler ambient which doesn't exceed 131°F/55°C.



### WARNING: Risk of fire

Despite careful construction, electrical devices can cause fires.

- Do not install the inverter in areas containing highly flammable materials or gases.
- Do not install the inverter in potentially explosive atmospheres.
- Install on a wall or strong structure capable of bearing the weight of the machine (14kg).
- Install vertically with a maximum incline of +/- 5 degrees, exceeding this may cause output power derating.
- To avoid overheating, always make sure the flow of air around the inverter is not blocked. A minimum clearance of 400mm should be kept between inverters or objects and 800mm clearance between the bottom of the machine and the ground.

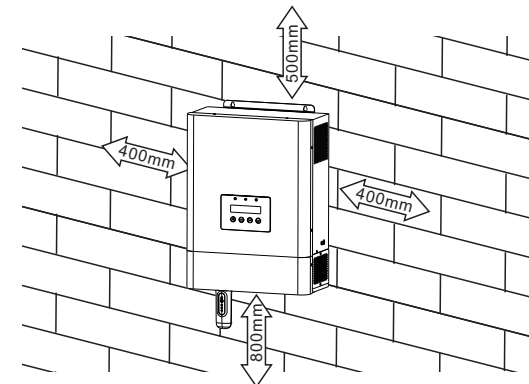

Figure 3.1 Inverter Mounting Clearance

- Visibility of the LEDs and LCD should be considered.
- Adequate ventilation must be provided.



### NOTE:

Nothing should be stored on or placed against the inverter.

# 3. Installation

## 3.2 Mounting the Inverter



**WARNING:**

The inverter must be mounted vertically.

Select the mounting height of the inverter and mark the mounting holes. It's recommended to install the inverter tighten by using two M5 screws.

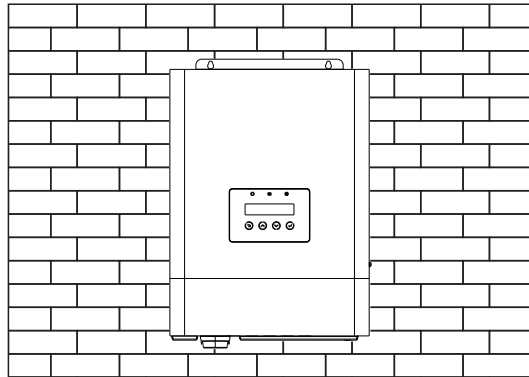

Figure 3.2 Wall Mount Inverter

Fix the two holes on the top of the machine and one hole in the box with screws.

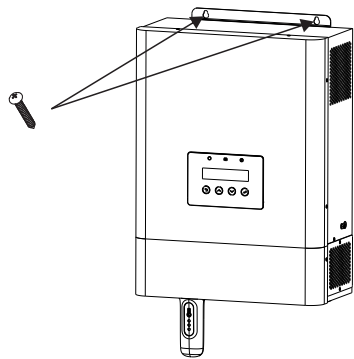

Figure 3.3 Fix inverter on the wall

# 3. Installation

## 3.3 Preparation

Before connecting all wiring, please take off the bottom cover by removing the screws as shown below.

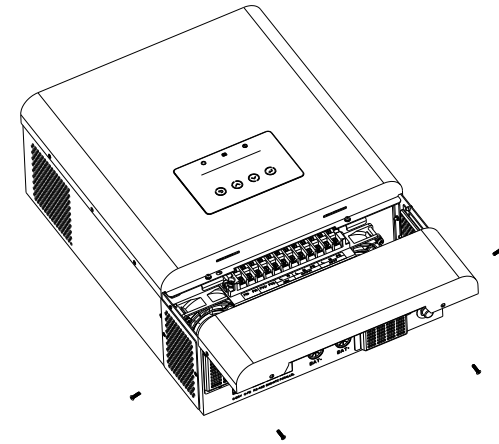

Figure 3.4 Remove the Junction Box Cover

# 3. Installation

## 3.4 PV Input Terminal Assembly

Please ensure the following before connecting the inverter:

- Make sure the voltage of the PV string will not exceed the max DC input voltage (500Vdc). Violating this condition will void the warranty.
- Make sure the polarity of the PV connectors are correct.
- Make sure the battery, AC Input, and AC Output are all in their off-states.
- Make sure the PV resistance to ground is higher than 20K ohms.
- Before connecting to PV modules, please install separately a DC circuit breaker between inverter and PV modules.

PV wire diameter requirements: 10AWG(5.26mm<sup>2</sup>).

1. Remove insulation sleeve 10mm for positive and negative conductors.
2. Insert the wire into the sleeve and use a suitable crimping tool for crimping.

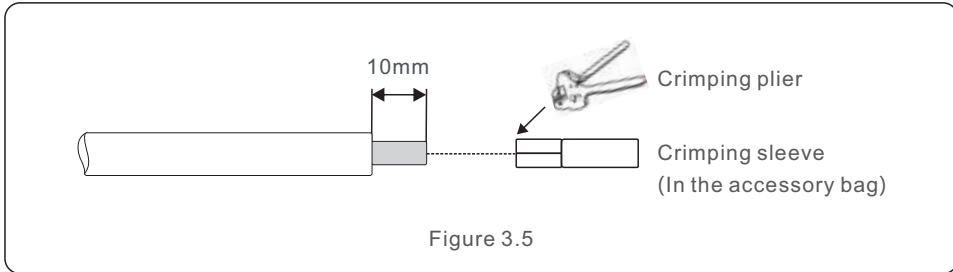

Figure 3.5

3. Please ensure the secure and correct polarity connection between PV modules and PV input connectors or the system will be damaged. Connect the positive pole (+) of the connection cable to the positive pole (+) of the PV input connector. Connect the negative pole (-) of the connection cable to the negative pole (-) of the PV input connector.

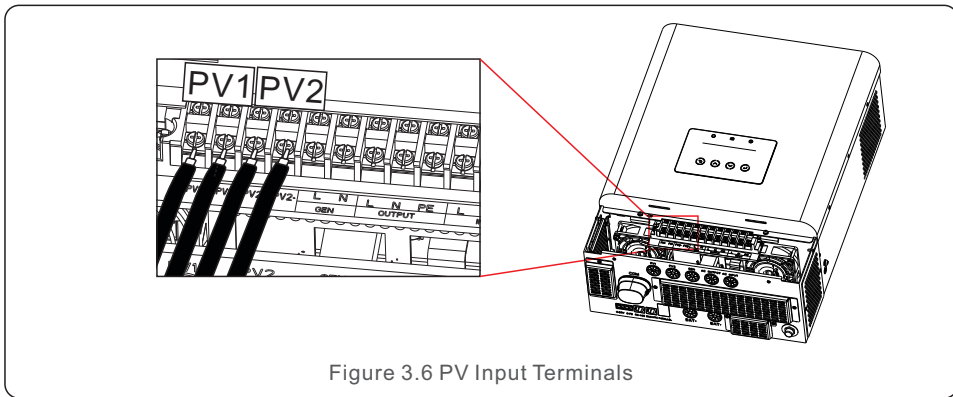

Figure 3.6 PV Input Terminals

# 3. Installation

## 3.5 Assembling the AC Connector

To protected from over current of AC input, Solis recommends installing a separate AC breaker between the inverter and the AC input power source.

This AC breaker should be at least 32A.

1. Ensure the cables are within the suitable specifications as shown in the table below:

	Item	Cable Size (AWG)	Cable Size (Cross Section)	Torque
AC Input	PE	10	5.3mm <sup>2</sup>	1.2-1.6Nm
	L	10	5.3mm <sup>2</sup>	1.2-1.6Nm
	N	10	5.3mm <sup>2</sup>	1.2-1.6Nm
AC Output	PE	10	5.3mm <sup>2</sup>	1.2-1.6Nm
	L	10	5.3mm <sup>2</sup>	1.2-1.6Nm
	N	10	5.3mm <sup>2</sup>	1.2-1.6Nm

Table 3.1 AC Wire Specification

2. Remove the 10mm insulation sleeve for the positive and negative conductors.
3. Insert the wire into the sleeve and use a suitable crimping tool for crimping. (see Figure 4.6)
4. Insert the AC input wires according to polarities indicated on terminal block and tighten the terminal screws. Ensure that the PE protective conductor is connected first. The connection sequence should be PE/L/N.

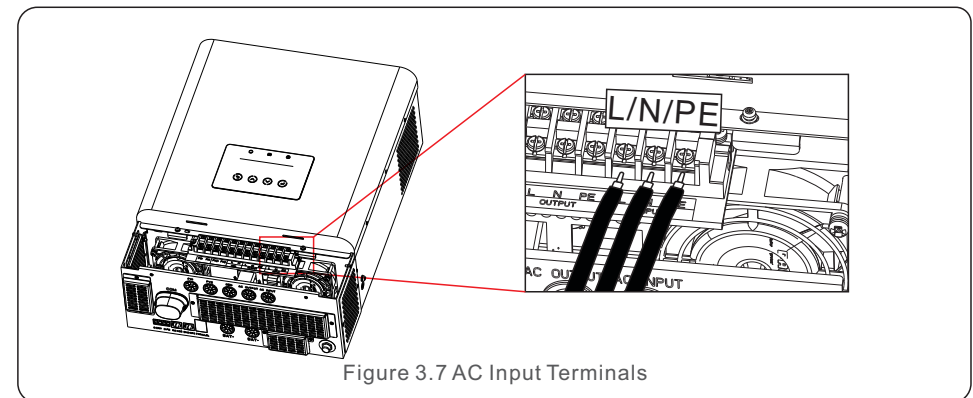

Figure 3.7 AC Input Terminals

# 3. Installation

5. Insert AC output wires according to polarities indicated on terminal block and tighten terminal screws with the torque of 1.2-1.6Nm. The connection sequence should be PE-L-N.

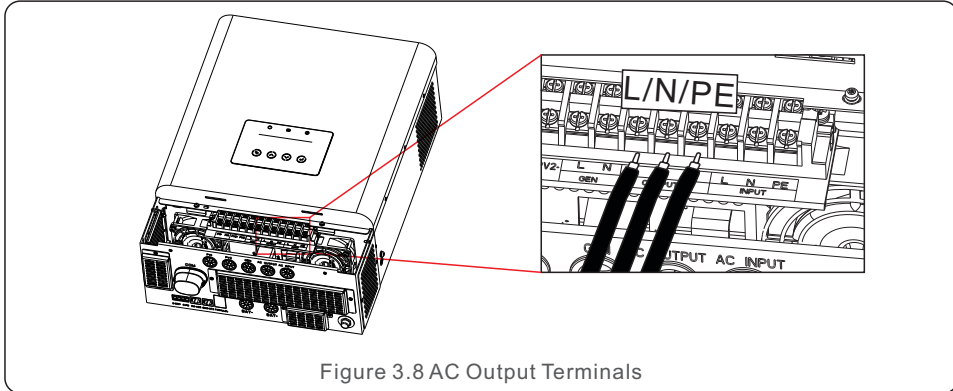

Figure 3.8 AC Output Terminals

6. Ensure the wires are securely connected.



**WARNING:**

Be sure to connect AC wires with correct polarity. If L and N wires are connected in reverse, it may cause utility short-circuit when inverters are working in the parallel operation.



**NOTE:**

An automatic disconnect device which complies with EN62109-2 standard should be installed on the outside of the AC input port.



**NOTE:**

AC Breaker recommended size: 50A.

# 3. Installation

## 3.6 Grounding

To effectively protect the inverter, a grounding methods must be performed. Connect the external grounding terminal.

To connect the grounding terminal on the heat sink, please follow the steps below:

1. Remove insulation sleeve 10 mm for positive and negative conductors.
2. Insert the wire into the sleeve and use a suitable crimping tool for crimping.
3. Connect the grounding cable to the grounding point on the heat sink and tighten the grounding screw. The torque rating is 1.0-1.2Nm.

Item	Cable Size (AWG)	Cable Size (Cross Section)	Torque
PE	12	3.3mm <sup>2</sup>	1.0-1.2Nm

Figure 3.9 Grounding connection

# 3. Installation

## 3.7 Battery Terminal Components

### 3.7.1 Lead-acid Battery

If you choose a lead-acid battery, the allowed battery types are AGW-type, flooded-type and Gel-type. The battery voltage to connect with the inverter is 48V. Considering the installation environment and operation safety, please pay attention to the following points:

- The natural surrounding ventilation of a Lead-acid battery should be sufficient and the environment temperature is within 25±10°C.
- Fix the bolts of the wire terminal ensure a good connection and to prevent the battery from sparking. The battery should avoid direct sunlight.
- Do not put the batteries in an environment with excessive radiation, infrared radiation, ultraviolet radiation, organic solvent gas, and corrosive gas.
- Batteries with different capacity and functionality can't be interconnected with each other.
- Check the battery voltage and polarity before connecting it to the inverter and turning on the system.
- Ensure the installation site has enough PV generation to support the battery system.

### 3.7.2 Lithium Battery

If you choose a lithium battery, you are allowed to use Pylontech, BYD and Dyness. Other batteries are available but please check the battery compatibility document available on [www.solisinverters.com](http://www.solisinverters.com)

Considering the installation and operation safety, please pay attention to the following points:

- Before completing the final DC connection or closing DC breaker, please ensure the correct polarity of the battery connection and positive (+) must be connected to BAT (+) and negative (-) must be connected to BAT (-).
- Please carefully read the user manual of the battery and strictly follow the precautions in the battery manual.



**NOTE:**

Please note it is integrated with a 70 Vdc, 150A fuse (non-delay) on the battery input side to protect electrical equipment from overcurrent. DC Breaker recommended size: 150A

# 3. Installation

## 3.7.3 Battery Connection

To avoid DC Arcs, Solis recommends installing a DC switch between the battery(s) and inverter.

Ensure the cables within the suitable specifications as shown in the table below.

	Item	Colour	Cable Size (AWG)	Cable Size (Cross Section)	Torque
Battery	BAT+	Red	4-2	21.2-33.6mm <sup>2</sup>	2.0-3.0Nm
	BAT-	Black	4-2	21.2-33.6mm <sup>2</sup>	2.0-3.0Nm

Table 3.2 Battery Power Cable Requirement

Insert the ring terminal of the battery cable flat onto battery connector of the inverter and ensure the bolts are tightened with a torque rating of 2.0-3.0Nm.

Ensure the polarity at both the battery and the inverter are correctly connected and the ring terminals are tightly screwed to the battery terminals.

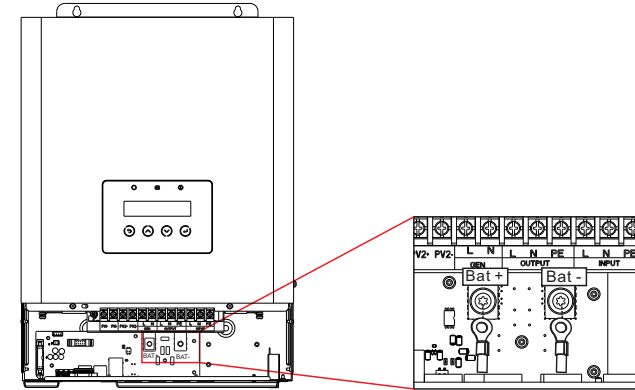

Figure 3.10 Battery Terminal Connections



**NOTE:**

Before connecting the battery, please carefully read the user manual of the battery and perform the installation exactly as the battery manufacturer requests.

# 3. Installation

## 3.8 Battery Communication

The EO Series inverter uses RS485 cable to communicate with BMS/NTC port to communicate with the BMS of Lithium and NTC of Lead-acid battery.

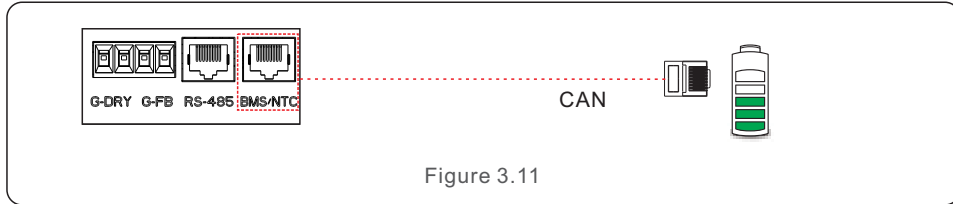

Figure 3.11



**NOTE:**

NTC temperature sensor should be attached to the surface of the lead-acid battery for detecting the temperature in real time.

### Procedure for Connecting the BMS Cable or NTC Cable:

If it is connected to a lithium battery, please take out the BMS communication cable from the accessory package. Connect one side of the cable to the battery and the other side to the BMS/NTC port;

If it is connected to a lead-acid battery, please take out the NTC communication cable from the accessory package. Connect the RJ45 side of the cable to the BMS/NTC port, and put the other side with the ring near the negative pole of the battery.



**NOTE:**

Lead-Acid and other older-technology battery types require experienced and precise design, installation and maintenance to work effectively. For lead-acid battery, battery SOC calculation may not be accurate according to battery in conformity between cells, battery aging or other specifications of lead-acid battery etc.

### BMS/NTC PIN Definition

Communication interface between inverter and battery is RS485 with a RJ45 connector.

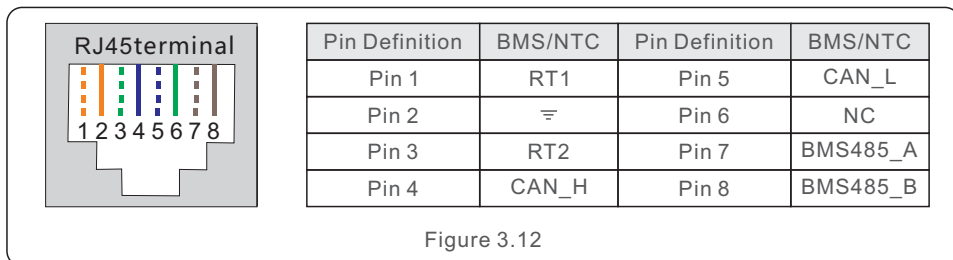

Figure 3.12

# 3. Installation

## 3.9 External Communication

RS-485 is one standard communication interface which can transmit the real data from inverter to PC or other monitoring equipments.

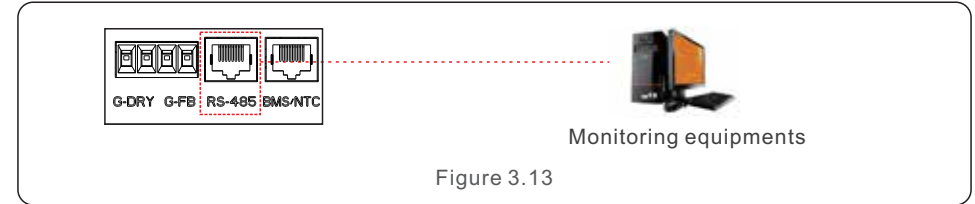

Figure 3.13

### Procedure for Connecting the RS485 Cable:

User can use the RS-485 port for external communication.

User should prepare the Comm-cable by themselves according to the pin-definition sheet shown as below.

The insert terminal need to use the RJ45 plug.

Insert one side of the cable into the RS-485 port of the inverter, and insert another side into PC or other monitoring device.

### RS485 PIN Definition

Communication interface between inverter and external device is RS485 with a RJ45 connector.

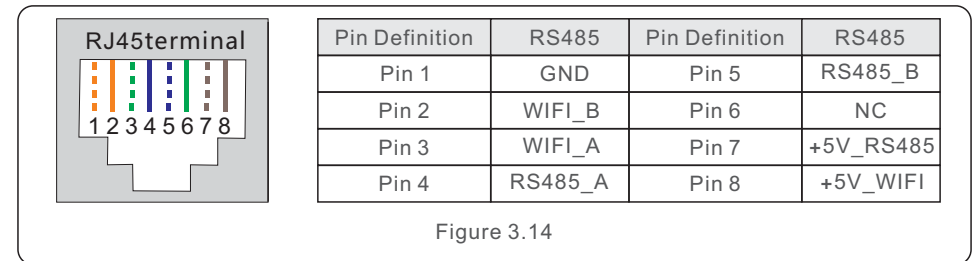

Figure 3.14

# 3. Installation

# 3. Installation

## 3.10 Generator Connection

S6 off-grid storage inverter is designed to operate in pure off grid condition or where the grid is unstable. AC Generator can be connected in the system to work with S6 off-grid storage inverter as an alternative backup source. The AC Generator can be connected in two positions, either on the AC Input port or the GEN port of the inverter.

### Option 1: Generator on the AC Input Port

AC Generator can be connected on the AC input port of the S6 off-grid storage inverter. There is no need to install extra communication wires. In a place where the grid is unstable, external auto transfer switch can be installed to switch between grid connection and generator connection when necessary.



**NOTE:**

If the generator is connected, it is not allowed to enable the Allow export.

### Option 2: Generator on the GEN port

S6 off-grid storage inverter is designed with a dedicated generator input port which can actively control the generator operation together with the generator input/output communication signals.

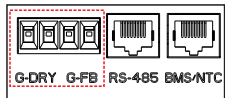

PIN Definition	Function
Pin1-(G-DRY)	Generator Control Output Signal (For controlling generator ON/OFF)
Pin2-(G-DRY)	
Pin3-(G-FB)	Reserved
Pin4-(G-FB)	

Figure 3.15



**NOTE:**

The recommended power of generator is 1.0-1.5 times the rated power of the inverter. However, generators with other power ratings can also be used, which may trigger generator shutdown due to the power of the backup load, but will not damage the generator or inverter.

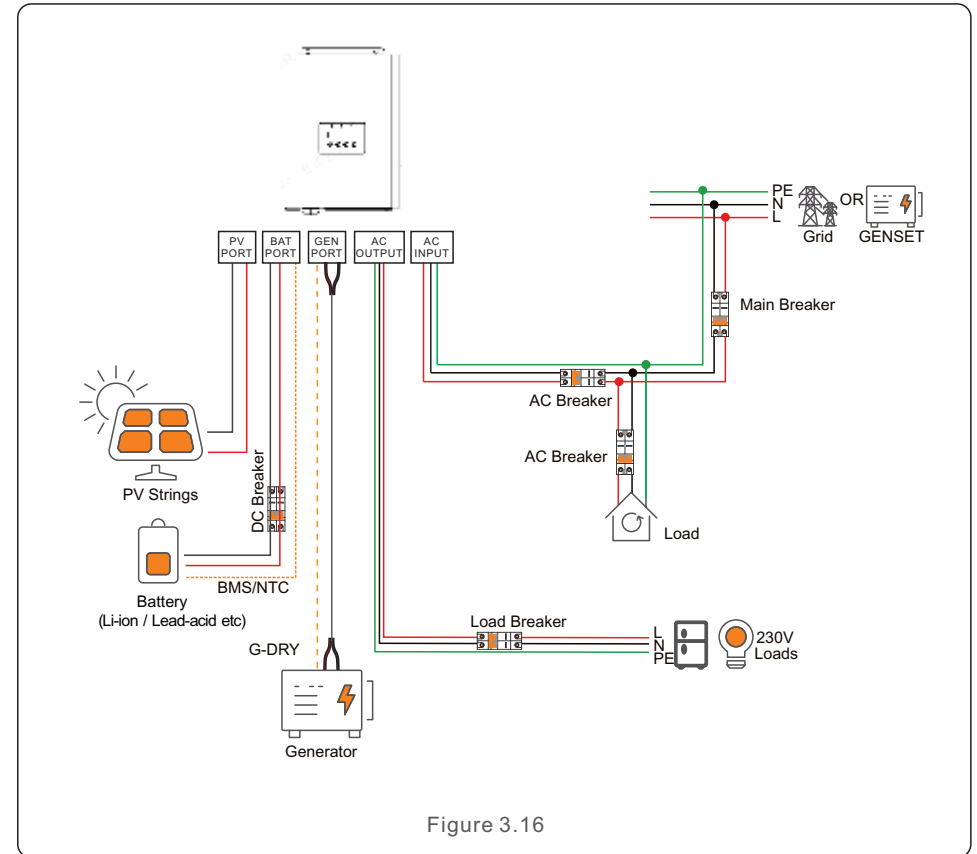

Figure 3.16

# 3. Installation

## 3.11 AC Coupling Connection

The AC Output port of the S6 off-grid storage inverter is capable of connecting loads as well as connecting PV grid tied inverter. The S6 off-grid storage inverter can dynamically increase the AC frequency in linearly relationship on the AC Output Port when battery is close to full. PV grid tied inverters, which support frequency-power response, can passively respond to the frequency change and adjust their generating power. In this way, S6 off-grid storage inverter can control the PV grid tied inverter's power without a physical communication cable in between.

The PV inverter should correctly set the overfrequency derating point to match the S6 off-grid storage inverter's AC coupling setting, otherwise the S6 off-grid storage inverter may not be able to correctly control the power of the PV inverter.



**WARNING:**

To use this function, please contact the manufacturer of the PV grid tied inverter to confirm the capability and configuration steps of the frequency-power response. Then adjust the AC coupling settings of S6 off-grid storage inverter accordingly. Solis is not responsible for any damages due to wrong configuration when using this function.

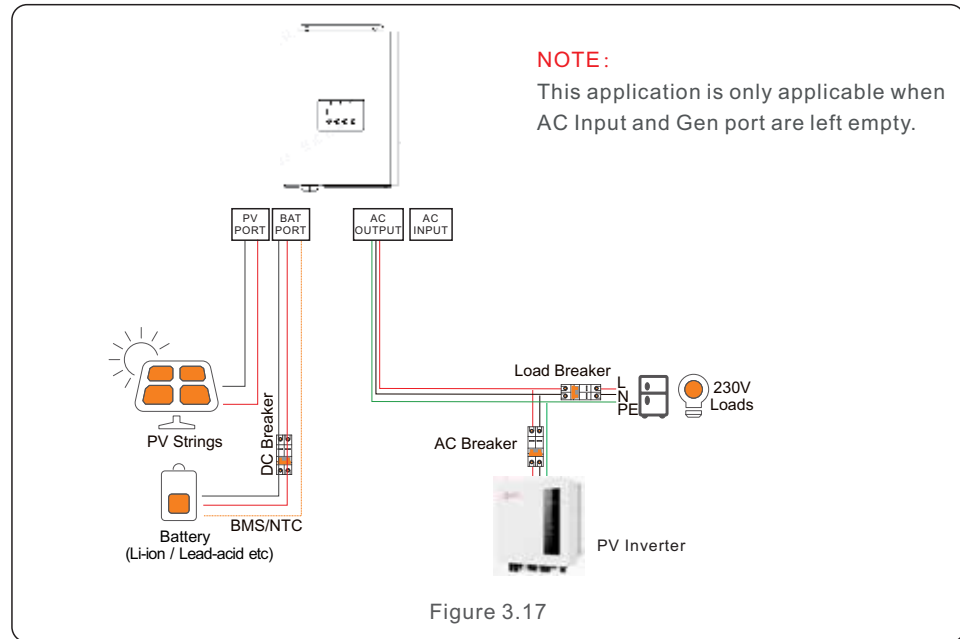

# 3. Installation

## 3.12 Parallel Connection

S6 off-grid storage inverter supports multiple kinds of parallel connection. Customers can flexibly utilize the parallel functions to expand the system capacity.

System	Support Parallel Port	Limitations
Single Phase System Parallel	AC Input Port, AC Output Port, Battery Port, GEN Port	Max 6 Units of Inverter can be connected in parallel
Three Phase System Parallel	AC Input Port, AC Output Port, Battery Port, GEN Port	Max 3 Units of Inverter can be connected in parallel (1 Unit per Phase)



**WARNING:**

All inverters in the parallel system MUST be with the same model/same power rating.



**WARNING:**

When operating in parallel condition, if using the GEN port to connect the generator, all inverters' GEN port MUST be connected in parallel and then connect to a single generator. (The G-DRY signal wire needs to be connected to the MASTER inverter of the system). It is not supported to connect multiple individual generators to each inverter's GEN port when the system is running in parallel.



**WARNING:**

When operating in parallel condition, if using the Battery port to connect the battery, all inverters' Battery port MUST be connected in parallel and then connect to a single battery bank (The BMS communication or NTC wire needs to be connected to the MASTER inverter of the system). It is not supported to connect multiple individual battery units to each inverter's battery port when the system is running in parallel.



**WARNING:**

Please carefully size the cable, DC breaker and AC breaker specification according to the actual capacity of the parallel system.



**NOTE:**

The parallel communication cable needs to be connected in daisy chain among all inverters in the parallel system. Two RJ45 parallel ports are provided at the bottom of the inverter for parallel communication.

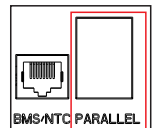

# 3. Installation

# 3. Installation

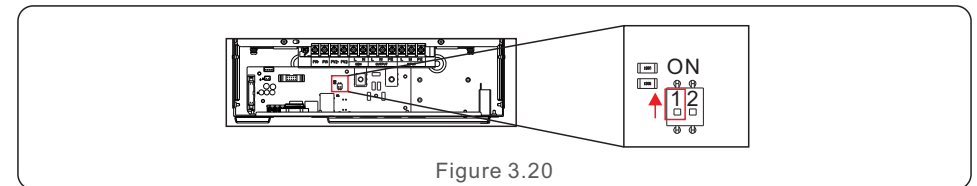
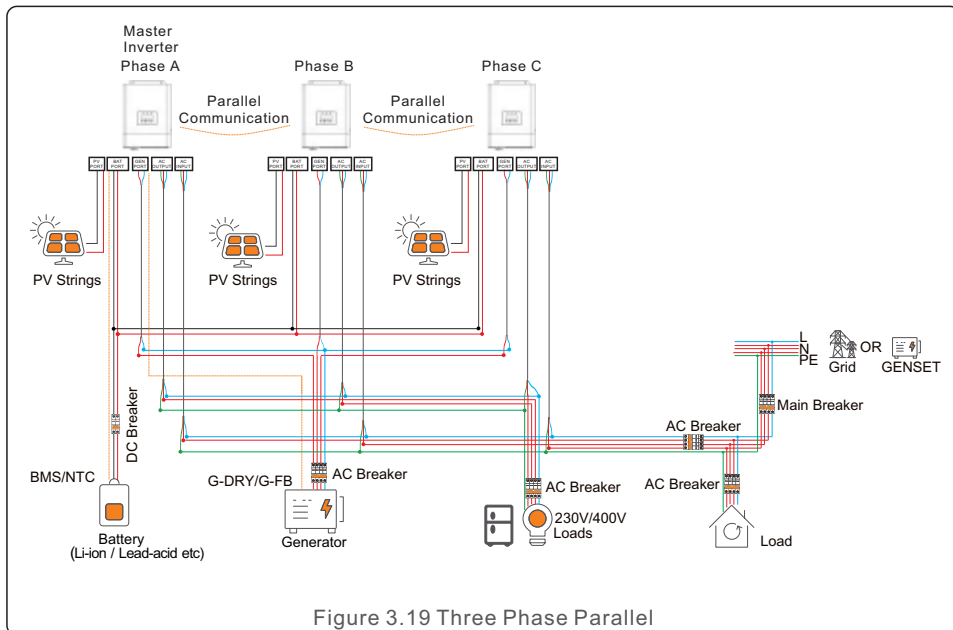
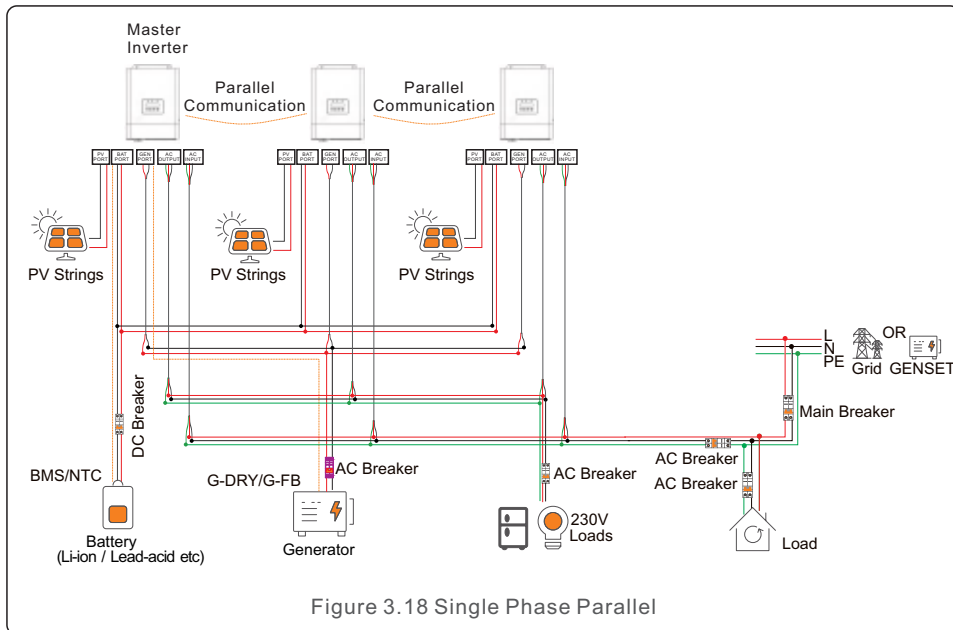

**NOTE:**

When a single inverter is running, DIP switch 1 and 2 shall be both at the bottom position.

When multiple inverters are paralleled, DIP switch: both the master inverter and the last slave inverter need to have 2 DIP switches enabled (Both Pin1 & Pin2).

### 3.13 External Communication Stick Connection

Inverter provides a Monitoring port which can collect data from inverter and transmit it to monitoring-website via an external monitoring data collector.

For details please refer to WiFi Stick Data logger Quick installation guide.

### 3.14 LED Indicates

There are three LED indicators on the inverter which indicate the working status.

Light	Color	Status	Description
STATUS	Green	FLASHING	The inverter is in standby(Slow flashing for 3S). The inverter is in self-test(Fast flashing for 0.5S).
		ON	The inverter is normal operation. Or The inverter is operating normally.
		OFF	The inverter is deenergized.
BATTERY	Green/Yellow	GREEN FLASHING	Battery is charging.
		GREEN CONSTANT	Battery is discharging.
		OFF	Battery is not installed or in the off position.
		YELLOW CONSTANT	Battery failure.
ALARM	Yellow/Red	YELLOW CONSTANT	There is an alarm but system is operational.
		RED CONSTANT	There is an alarm and the system has stopped.
		OFF	No Alarm.

Table 3.3 Status Indicator Lights

# 4. Commissioning

## 4.1 Preparation of Commissioning

- Ensure all the devices are accessible for operation, maintenance and service. Check and confirm that the inverter is firmly installed.
- Ensure space for ventilation is sufficient for one inverter or multiple inverters.
- Ensure Nothing is left on top of the inverter or battery module.
- Ensure inverter and accessories are correctly connected.
- Ensure cables are routed in a safe location or protected against mechanical damage.
- Ensure warning signs and labels are suitably affixed and durable.

## 4.2 Commissioning Procedure

If all the items mentioned above meet the requirements, proceed as follows to start up the inverter for the first time.

1. Switch on the AC-Output and AC-Input.
2. Refer to "Part 5" to configure the parameters. Ensure to run through the Startup Wizard.
3. Switch on the DC circuit breaker between inverter and battery.
  - a. If the battery equipped is Pylon Li-ion Battery, actuate the switch on the battery manually. The relay will make 'clicking' sounds and it will take a short-time to work automatically.
4. Verify the system is working properly.
5. Proceed to setup the systems communication and refer to the datalogger manual.
  - a. All manuals can be found at [www.solisinverters.com](http://www.solisinverters.com)

# 5. Operation

## 5.1 Startup guide

Please follow the steps to complete the initial setup process.

Steps:

Start-up Wizard Language > Time > Connect battery > Battery Type > Connect generator > Back up setting > Setting successfully

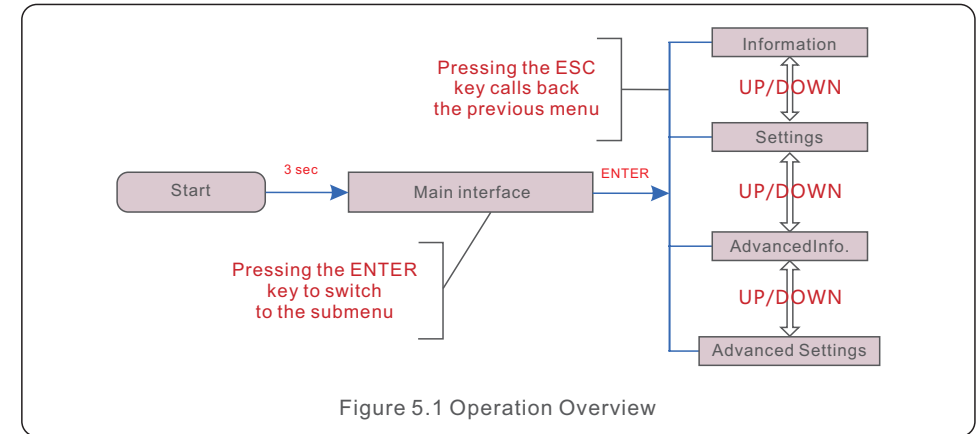

Figure 5.1 Operation Overview

## 5.2 Main Menu

There are four submenu in the Main Menu (see Figure 5.1):

1. **Information**
2. **Settings**
3. **Advanced Info.**
4. **Advanced Settings**

## 5.3 Information

In the information section, operating data and information data can be viewed.

Sub-sections include:

1. **General Information**
2. **System Information**
3. **Energy Records**
4. **BMS information**

# 5. Operation

## 5.3.1 General Information

The example displays are shown in the following figures. The user can view it by pressing the up and down keys. Values are for reference only.

Display	Description
Inverter SN: 00000000000000	Shows the inverter serial number.
Model. : S6-E01P5K-48	Shows the model of the device.
SoftVer. : 040000	Shows the DSP and ARM version of the inverter.
HMI Software	ARM version of the inverter.

Figure 5.2 General Information

## 5.3.2 System Information

The example displays are shown in the following figures. The user can view it by pressing the up and down keys. Values are for reference only.

Display	Description
V_DC: 000.0V I_DC: 000.0A	Shows the voltage on DC side. Shows the current on DC side.
V_AC: 000.0V I_AC: 000.0A	Shows the voltage on AC side. Shows the current on AC side.
Grid Frequency: 00.00Hz	Shows the grid frequency value.
Battery V: 000.0V Battery I: 000.0A	Shows the battery voltage. Shows the battery current.
Backup V: 000.0V Backup P: 00.0kW	Shows the voltage on backup. Shows the power on backup.
Charge P: 00.0kW DisCharge P: 00.0kW	Shows the charging power. Shows the discharging power.
Gen P:	Show the power of generator

Figure 5.3 System Information

# 5. Operation

## 5.3.3 Energy Records

Sub-sections of the Yield information section include:

1. Battery Yield
2. Grid Yield
3. Load Yield

The example displays are shown in the following figures. Values are for reference only.

Display	Description
BattChgE Total: 0000000kWh	Shows the total battery charged energy.
BattChgE Today: 000.0kWh	Shows today's battery charged energy.
BattChgE Lastday: 000.0kWh	Shows yesterday's battery charged energy.
BattDisChgE Total: 0000000kWh	Shows the total battery discharged energy.
BattDisChgE Today: 0000000kWh	Shows today's battery discharged energy.
BattDisChgE Lastday: 0000000kWh	Shows yesterday's battery discharged energy.

Figure 5.4 Battery Yield

Display	Description
GridGetE Total: 0000000kWh	Shows the total energy received from the grid.
GridGetE Today: 000.0kWh	Shows today's energy received from the grid.
GridGetE Lastday: 000.0kWh	Shows yesterday's energy received from the grid.

Figure 5.5 Grid Yield

Display	Description
LoadE Total: 000000kWh	Shows total load energy.
LoadE Today: 000.0kWh	Shows today's load energy.
LoadE Lastday: 000.0kWh	Shows yesterday's load energy.

Figure 5.6 Load Yield

Display	Description
PVE Total: 000.0kWh	Shows total energy received from PV.
PVE Today: 000.0kWh	Shows today's energy received from PV.
PV E Lastday: 000.0kWh	Shows yesterday's energy received from PV.

Figure 5.7 PV Yield

Display	Description
GEN E Today: 000.0kWh	Shows the today energy received from the generator.
GEN E Total: 000.0kWh	Shows the total energy received from the generator.

Figure 5.8 GEN Yield

## 5.3.4 BMS Information

The example displays are shown in the following figures.

The user can view it by pressing the up and down keys.

Values are for reference only.

Display	Description
Battery V: 00.00V Battery I: +00.00A	Battery V: Shows battery voltage(From BMS). Battery I: Shows battery current(From BMS).
ChargeLmt: 000.0A DischargeLmt: 000.0A	ChargeLmt: Shows battery charge limit(Current). DischargeLmt: Shows battery discharge limit(Current).
ChargeVLmt: 000.0A DischargeVLmt: 000.0A	ChargeLmt: Shows battery charge limit(Voltage). DischargeLmt: Shows battery discharge limit(Voltage).
SOC Value: 000% SOH Value: 000%	SOC value: Shows battery state of charge. SOH value: Shows battery state of health..
BMS Status: CAN Fail	Shows that Battery BMS communication status.
BMS Version: 0.0	Shows that Battery BMS version.

Figure 5.9 BMS Information

BMS ONLY support CAN communication not RS485, and all the data will display "0" when the battery has been selected as Lead-acid battery which is monitored by NTC in CAN/NTC port.

# 5. Operation

## 5.4 Settings

The following submenus are displayed when the Settings menu is selected:

1. Set Time/Date
2. Set Address
3. Set Mute
4. Mode Settings

### 5.4.1 Set Time/Date

This function allows time and date setting. When this function is selected, the LCD will display a screen as shown in Figure 5.10.

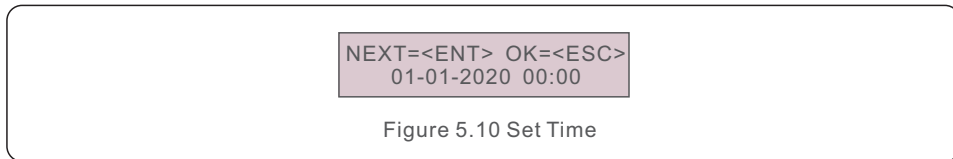

Figure 5.10 Set Time

### 5.4.2 Set Address

This function is used to set inverter address for data logger connection/modbus communication/parallel connection.

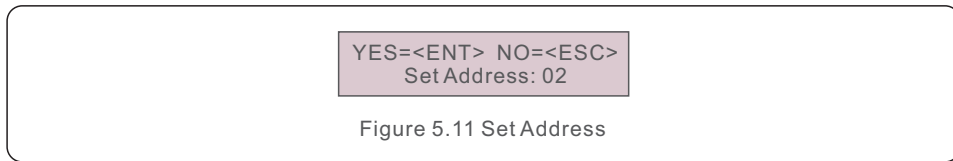

Figure 5.11 Set Address

### 5.4.3 Set Mute

This function allows you to turn on/off the keypad tone and buzzer sound. Select YES to disable the sound and select NO to enable the sound. Default is "YES".

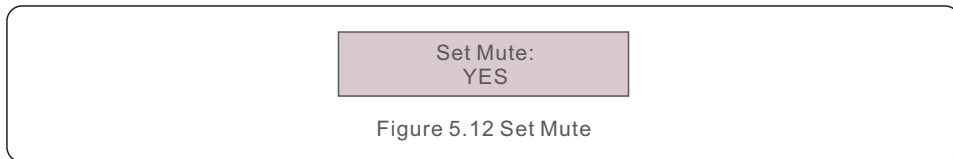

Figure 5.12 Set Mute

# 5. Operation

## 5.4.4 Mode Settings

This section describes the working logic of each work mode of the inverter.

Display	Description
Work Mode: Self Use	Self-Use Mode stores the excess PV power into the battery. If the battery is charged, or there is no battery, the excess PV power will be exported(sold)back to the utility company. If the system is set to not export any power, then the inverter will curtail the PV power(derate the inverter output power).
Self use Switch: Enable/Disable	The switch is to enable/disable the self-use mode.
Time of Use Switch: Enable/Disable	The switch is to enable/disable the Time of use setting to allow user to set a customized charging/discharging pattern.
Time of Use chg curr	To Set the Charge Current for battery in the state of time of use.
Time of Use Disch Curr	To Set the Discharge Current for battery in the state of time of use.
Chg Tim Slot 1-6: Start/stop	To Set the customized charging/discharging time period. Inverter will follow self-use logic during undefined time period. These settings are only effective when Time of Use Switch is enabled.
Dischg Tim Slot 1-6: Start/stop	
AllowGridCharging: Enable/Disable	To Set if the system is allowed to use grid power to charge the battery.
BatReserve Switch: Enable/Disable	To Set if the system needs to reserve a certain SOC of battery during normal operation and only to be used when grid is lost to support the load for a longer time.
Reserved SOC Set	Reserved SOC. Only effective when Battery Reserve Switch is enabled.
Grid Charge Power Limit	The max power limit from grid can be used to reserve the battery SOC level. Only effective when Battery Reserve Switch is enabled.

Figure 5.13 Work Mode

Display	Description
Work Mode: Off-Grid	Off-Grid Mode is only to be used by systems that are not electrically connected to the grid at all. This mode is like Self-Use Mode, but the PV power will be curtailed if the battery is charged and the home load demand is lower than the amount of available PV power.
OffGrid Switch: Enable/Disable	The switch is to enable/disable the off grid mode.
Offgrid overdiasharge SOC	To set the overdischarge SOC of the battery under off grid condition.

Figure 5.14 Work Mode

 **NOTE:** Due to the sampling interval limitation, when the system's load consumption has sudden changes, small amount of export overshooting is expected. For strict zero injection applications, it is suggested to install external backflow trip device as additional protection for injection or use off-grid mode.

 **NOTE:** The set current value in TOU function is the maximum current for charging/ discharging the battery. However the actual charging/discharging current may not reach this value due to the influence of other factors, such as the maximum charging/discharging power limitation of the inverter, the battery BMS limitation, etc.

 **NOTE:** For lead-acid or non-communicated lithium batteries, Solis inverters are using measured battery voltage to estimate the battery's state of charge(SOC). Due to measurement accuracy and different batteries' behaviours, Solis's estimated battery SOC parameter is for reference only. Solis does not guarantee the accuracy for this parameter.

## 5.5 Advanced Information

 **NOTE:** This area is for fully qualified and accredited technicians only.

Enter the password 0010 to access to the following sections.

1. Alarm Message
2. Warning Message
3. Running Status
4. Communication data
5. Yield Profile

YES=<ENT> NO=<ESC>  
Password:0000

Figure 5.15 Enter Password

The screen can be scrolled by pressing the UP/DOWN keys. Pressing the ENTER key gives access to a submenu. Press the ESC key to return to the Main Menu.

### 5.5.1 Alarm Message

The display shows the 500 latest alarm messages. Screens can be scrolled by pressing the UP/ DOWN keys.

Alm000: NO-Grid  
T:01-01 00:02 D:0000

Figure 5.16 Alarm Message

Press the ESC key to return to the previous menu. Press the ENTER key to return to the next menu. The example displays are shown in the following figures. Values are for reference only.

# 5. Operation

## 5.5.2 Warning Message

The display shows the warning messages appeared on screen, can store in total 500pcs. Press the ESC key to return to the previous menu.

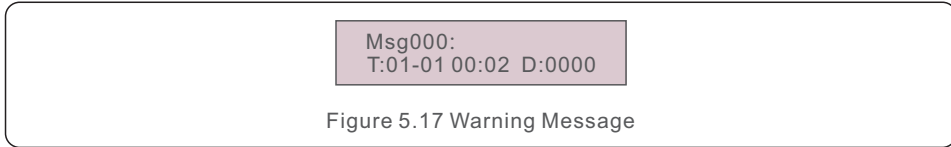

Figure 5.17 Warning Message

## 5.5.3 Running Status

This section is for maintenance personnel to view the running information (Values are for reference only).

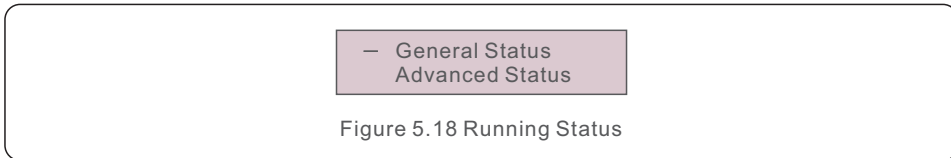

Figure 5.18 Running Status

Display	Description
DC Bus Voltage: 0.0V	Shows DC bus voltage.
Power Factor: +0.000	Shows power factor of the inverter.
Power Limit%: 000%	Shows the power output percentage of the inverter.
Inverter Temp: +0.0degC	Shows heat sink temperature of the inverter.
Grid Standard:	Shows grid standard.
Flash State: 11111111	Shows the data migration time.

Figure 5.19 General Status



**NOTE:**

The advanced status is reserved for Solis technicians.

# 5. Operation

Display	Description
Ground Voltage: 000.0V	Shows the voltage to the ground.
Relay-Fault Func.: RUN	Shows the status of the relay.
GRID-INTF.02 Func.: RUN	Shows the interference status from the grid.

Figure 5.20 Advanced Status

## 5.5.4 Communication data

This section shows the communication data between HMI and DSP. For Solis engineers ONLY.

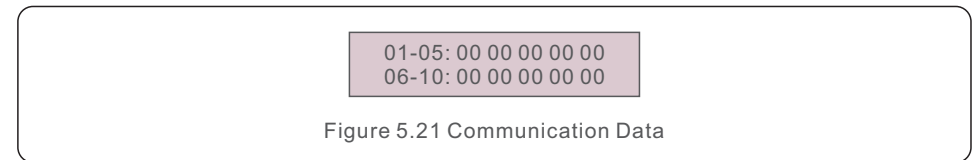

Figure 5.21 Communication Data

# 5. Operation

## 5.5.5 Yield Profile

### 5.5.5.1 Energy Battery

Shows the battery charge & discharge energy.

Display	Description
Battery Charge	Shows the battery charge energy.
Battery Discharge	Shows the battery discharge energy.

Figure 5.22 Battery Charge

### 5.5.5.2 Grid Energy

Energy received from the grid. or Energy from the grid.

Display	Description
Energy Received	Shows the energy received from the grid.

Figure 5.23 Energy Received from Grid

### 5.5.5.3 Energy Backup

Energy provided from backup port.

Display	Description
Daily Energy	Shows the daily energy.
Monthly Energy	Shows the monthly energy.
Yearly Energy	Shows the yearly energy.

Figure 5.24 Energy Backup

# 5. Operation

## 5.6 Advanced Settings



### NOTE:

This area is for fully qualified and accredited technicians only.

Enter the password 0010 to access to the following sections.

1. Backup Settings
2. Feed Grid Setting
3. Battery Settings
4. Special Settings
5. Parallel Settings
6. Generator Settings
7. AC Coupling Settings
8. Password Settings

YES=<ENT> NO=<ESC>  
Password:0000

Figure 5.25 Enter Password

The screen can be scrolled by pressing the UP/DOWN keys.

Pressing the ENTER key gives access to a submenu.

Press the ESC key to return to the Main Menu.

### 5.6.1 Backup Settings

Display	Description
Backup ON/OFF	When you select ON, AC output port is enabled. When you select OFF, AC output port is disabled.
Backup Voltage	Shows the backup voltage.
Backup Frequency	Shows the backup frequency.
Volt Droop	Voltage droop function when overload on backup port.
Min.Droop V	Min allowed voltage for voltage droop function.

Figure 5.26 Backup Settings

## 5.6.2 Feed Grid Setting

Display	Description
Allow Feed in Grid: Enable/Disable	When you turn on the enable switch, excess energy is fed into the grid. When you turn off the enable switch, no energy is fed into the grid.

Figure 5.27 For Feed Grid Setting

 **NOTE:** The Feed Grid Setting enable switch can be turned on only when the utility grid allows the inverter to export power to the grid.

## 5.6.3 Battery Settings

The section has 2 parts:

1. Battery Select
2. Advanced Battery Settings

### 5.6.3.1 Battery Select

The battery selection includes the following 5 options:

1. Lithium battery
2. 48V Lithium battery (without comm)
3. 52.1V Lithium battery (without comm)
4. Lead Acid
5. No Battery

### 5.6.3.2 Advanced Battery Settings

The following is the setting of battery parameters. For different lithium batteries, the inverter has been set with the optimal battery configuration, and it is recommended that customers do not modify it without authorization.

For lead-acid batteries, the installer should set it according to the battery type.

**For lithium batteries, these are the following settings:**

Display	Description
Overdischar SOC	When battery reached overdischarge SOC, inverter will stop discharging the battery.
Force SOC Set	Due to selfdischarging, battery SOC may drop to lower than overdischarge SOC. When reached forcecharge SOC, inverter will charge the battery automatically to avoid battery entering sleep mode.

Figure 5.28 For Lithium Batteries

Display	Description
Max Charge Curr	To set the max allowed charge current.
Max Dischar Curr	To set the max allowed discharge current.
Battery Wakeup	To set the the type of battery wake.

Figure 5.29 For Lithium Batteries

There are two types of battery wake-up:  
Wake up Manually and Wack Up Automatic

Display	Description
Switch: ON/OFF	Manual Wakeup funcion. Inverter will charge the battery port at the wakeup voltage level and maintain for a certain time period in order to wakeup battery in sleep mode.
Voltage Set	Wake up voltage setting.
Time Set	Wake up time setting.

Figure 5.30 Wake up Manually

Display	Description
Wack Up Automatic: Enable/Disable	Automatic battery wake up function. Inverter will initiate the battery wake up function when it is powered up.
Auto Bat Awaken	Automatic battery wake up function. Inverter will initiate the battery wake up function when it is powered up.
Awaken Time Set	Wake up time setting.

Figure 5.31 Wack Up Automatic

Display	Description
Battery Healing switch: ON/OFF	To enable/disable the battery healing function. During low PV period, battery SOC may be kept low SOC for a long time. Battery healing function will charge the battery until the target SOC .
Battery Healing SOC	Target SOC for battery healing function, the value ranges from 80 to 100%. The default value is 100%.

Figure 5.32 Battery Healing

Display	Description
Force Power Set	Max grid power allowed for battery forcecharging.
ECO Function	To enable/disable the ECO function. When at night and battery SOC reached overdischarge SOC, inverter will shutdown the battery circuit to avoid battery power consumption.
Quick Charge	Enable the quick charge function, inverter will charge the battery at the max capability.

Figure 5.33 For Lithium Batteries

**For lead acid batteries, these are the following settings:**

Display	Description
Battery Capacity	Battery capacity in Ah.
Bulk Chg. Volt	Voltage setting for Constant voltage charging stage. Also called absorption voltage.
Overdischar Volt	When battery reached overdischarge voltage, inverter will stop discharging the battery.

Figure 5.34 For Lead Acid Batteries

Display	Description
Force Volt Set	Due to selfdischarging, battery voltage may drop to lower than overdischarge voltage. When reached forcecharge voltage, inverter will charge the battery automatically to avoid battery entering sleep mode.
Float Volt	Voltage setting for floating charging stage.
Batt equalization	This function is designed to realize the equalizing charging stage for the batteries. Whether to turn on this function, default is off.
Equalized time.	Equalizing Charging Time Period.
Equalized Volt	Equalizing Charging Voltage.
Equalized interval	Interval between equalizing charging.
Temp compem	Voltage-Temperature compensation coefficient.

Figure 5.35 For Lead Acid Batteries

## 5.6.4 Special Settings



These functions are for maintenance personnel only. Misuse of these functions could lead to equipment damage, inverter function or reduced inverter production.

The section has 8 parts:

1. Power Switch
2. Batt Line ZO
3. MPPT Multi-peak Scan
4. RisoLim
5. Daily PV-ISO-dec
6. Clear Energy
7. Restore Settings
8. AFCI Setting

# 5. Operation

## 5.6.4.1 Power Switch

When choose On, Inverter will generate power (default)  
When choose Off ,inverter stops generating.

Power Switch:  
ON

Figure 5.36 Power Switch Setting

## 5.6.4.2 Batt Line ZO

Batt Line ZO is the battery line impedance setting. The purpose is to compensate the resistance loss of the battery line. The default value is 10mΩ, 0-99mΩ can be set.

Batt Line ZO:  
10mΩ

Figure 5.37 Battery Line ZO Setting

## 5.6.4.3 MPPT Multi-peak Scan

Enable periodic MPPT scanning to track the global max power point of the system.

Display	Description
Scan Switch: Enable/Disable	Enable/Disable the scanning.
Scan Interval: 1800S	Set the scan interval.

Figure 5.38 MPPT Multi-peak Scan Setting

## 5.6.4.4 RisoLim

Set the PV insulation protection limit.

Display	Description
RisoLim	Set the PV insulation protection limit.

Figure 5.39 RisoLim Setting

# 5. Operation

## 5.6.4.5 Daily PV-ISO-dec

Enable/Disable the Daily PV-ISO Detection.

Display	Description
Daily PV-ISO-dec: Enable/Disable	Enable/Disable the Daily PV-ISO Detection.

Figure 5.40 Daily PV-ISO-dec Setting

## 5.6.4.6 Clear Energy

Clear Energy will reset the historical yield of the inverter.



This function is only for maintenance personnel.

## 5.6.4.7 Restore Settings

This section allows you to reset all the settings and bring the settings back to default values.

YES=<ENT> NO=<ESC>  
Are you sure?

Figure 5.41 Restore Settings

## 5.6.4.8 AFCI Protect

Display	Description
AFCI Protect: 01	Enable/Disable the Arc fault detection function.
Clear AFCI Fault: Enable/Disable	UL1699B Arc Fault Alarm Clear.

Figure 5.42 AFCI Protect Setting

# 5. Operation

## 5.6.5 Parallel Settings

Display	Description
Parallel Mode: Single/Parallel	To set if the inverter is running in single unit condition or parallel condition.
Physical Address ID	To set the physical address ID for parallel operation.
Set Master/Slave: Slave/Master	To set if the inverter is a master unit or slave unit in parallel operation.
Connected Phase: None/Single Phase/ Phase A(Three phase)/ Phase B(Three phase)/ Phase C(Three phase)	To set which phase the inverter is connected to.

Figure 5.43 Parallel Settings

## 5.6.6 Generator Settings

Display	Description
With Gen: Enable/Disable	To set if the system is connected with generator or not.
Gen Power Set: Gen Rated P/ Gen Max. Charge P	To set the generator rated output power.
Gen Position: Gen port/Grid port	To set position where the generator is connected.
Start-Stop SOC/V	To set the battery SOC /voltage at which the generator will step in or stop operation.
Gen signal: Enable/Disable	To set if the generator signal is available.
Gen Force: 0/1	To force start up the generator.
Gen Stop: 0/1	To force stop the generator.

Figure 5.44 Generator Settings

# 5. Operation

## 5.6.7 AC Coupling Settings

Display	Description
Switch: Enable/Disable	To enable/disable the AC coupling function to use frequency adjustment to control the PV inverter generation.
Position: Gen/Back Up	To set the position where the PV inverter is connected.
ON_SOC	When the battery SOC drops to this setting, the PV inverter starts to work.
ON_Bat_Volt	When the battery Volt drops to this setting, the PV inverter starts to work.
Start Frequency	When the battery SOC reaches ON-SOC, the inverter will first control the frequency to the start frequency, corresponding to the starting point of the inverter's overfrequency load reduction.
OFF_SOC	To set the AC coupling stop SOC at which the frequency will reach AC coupling Max.Fre.
OFF_Bat_Volt	To set the AC coupling stop Voltage at which the frequency will reach AC coupling Max.Fre.
Max.fre	The max frequency allowed in the system for controlling PV Inverter generation.

Figure 5.45 AC Coupling Settings

## 5.6.8 Password Settings

Input New Password: XXXX	Verify New Password: XXXX
-----------------------------	------------------------------

Figure 5.46 Password Settings

# 6. Maintenance

Solis EO series inverter do not require any regular maintenance. However, cleaning the heatsink will help the inverter dissipate heat and increase the lifespan. The dirt on the inverter can be cleaned with a soft brush.



**CAUTION:**

Do not touch the surface when the inverter is operating. Some parts may be hot and cause burns.

The LCD and the LED status indicator lights can be cleaned with cloth.



**NOTE:**

Never use any solvents, abrasives or corrosive materials to clean the inverter.

# 7. Troubleshooting

The inverter has been designed in accordance with international interconnection standards for safety and electromagnetic compatibility requirements.

Before delivering to the customer the inverter has been subjected to several test to ensure optimal operation and reliability.

In case of a failure the LCD screen will display an alarm message.

The alarm descriptions and their corresponding alarm messages are listed in Table 7.1:

When a fault occurs, the "Fault" state will be shown on the main screen.

Follow the steps below to check the fault status.

Steps: Enter → Down → Advanced Information → Enter Password → Enter → Down → Warning Message.

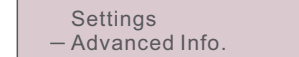

Figure 7.1 Advanced Information



Figure 7.2 Enter Password

Press DOWN to select Warning Message, the press ENTER.



Figure 7.3 Warning Messages

# 7. Troubleshooting

Alarm Message	Failure description	Solution
G_AB Over Volt G_BC Over Volt G_CA Over Volt G_AB Over Volt2 G_BC Over Volt2 G_CA Over Volt2 G_AB Trans Ov_V G_BC Trans Ov_V G_AB 10min Ov_V G_BC 10min Ov_V G_CA 10min Ov_V Grid Trans Ov_V	Grid Overvoltage	1. Resistant of AC cable is too high, Change AC cable for larger size. 2. Adjust the protection limit if it's allowed by electrical company.
G_AB Under Volt G_BC Under Volt G_CA Under Volt G_AB Under Volt2 G_BC Under Volt2 G_CA Under Volt2	Grid Undervoltage	1. Adjust the protection limit In user define setting if it's allowed by electrical company.
Grid Over Freq. Grid Over Freq.2	Grid Overfrequency	1. Adjust the protection limit In user define setting if it's allowed by electrical company.
Grid Under Freq. Grid Under Fre.2	Grid Underfrequency	1. Adjust the protection limit In user define setting if it's allowed by electrical company.
Grid Over Imp.	Grid Impedance is too large	1. Adjust the protection limit In user define setting if it's allowed by electrical company.
No Grid	NO Grid Voltage	1. Check connection and grid switch. 2. Check grid voltage on the inverter terminals.
Grid Unbalance	Grid voltage is unbalanced	1. Restart inverter or contact installers.
Grid Freq. Spark	Grid frequency is sparking	1. Check whether Grid is abnormal. 2. Confirm connection of AC cable is normal. 3. Restart System and ensure whether the fault is existing.
Grid A Over Curr Grid B Over Curr Grid C Over Curr Phase Over Curr	Grid overcurrent	1. Restart inverter. 2. Change power board.
Ig Tracking Err	Grid current tracking fail	1. Restart inverter or contact installers.
Pv1 Over Volt PV2 Over Volt PV3 Over Volt PV4 Over Volt	DC Overvoltage	1. Reduce the module number in series.
Bus Over Volt	DC Bus overvoltage	1. Check inductor connection of inverter. 2. Check driver connection.
Vbus Unbalance	DC Bus is unbalanced voltage	1. Restart System and ensure whether the fault is existing.

# 7. Troubleshooting

Alarm Message	Failure description	Solution
Bus Under Volt	DC Bus is undervoltage	1. Restart System and ensure whether the fault is existing.
Vbus Unbalance2	DC Bus is unbalanced voltage 2	1. Restart System and ensure whether the fault is existing.
Pv1 Over Curr	Pv1 overcurrent	1. Restart inverter. 2. Identify the fault and remove the strings from fault MPPT. 3. Change power board.
Pv2 Over Curr	Pv2 overcurrent	
PV Input Disturb	DC input disturbs	1. Restart inverter. 2. Change power board.
PV Connect Err	DC polarity reverse fault	1. Check whether the polarity of PV cable has reversed connection.
PV Mid Iso	PV midpoint grounding fault	1. Check whether PV strings have trouble in insulation.
Pv1 Under Volt	Pv1 undervoltage	1. Check whether the DC cable is damaged. 2. Restart system and ensure whether the fault is existing.
Pv2 Under Volt	Pv2 undercurrent	1. Check whether the DC cable is damaged. 2. restart system and ensure whether the fault is existing.
Vbus Sample Err	Bus voltage sampling fault	1. Restart System and ensure whether the fault is existing.
Boost Over Curr	Boost overcurrent	1. Restart System and ensure whether the fault is existing.
Grid Disturb	Gird disturbing	1. Restart inverter. 2. Change power board.
Dsp Init Err	DSP initializing protection	1. Restart inverter or contact installers.
Module Over Temp System Over Temp	Over temperature protection	1. Check whether the environment around inverter is poor heat dissipation. 2. Confirm whether inverter installation is satisfied with requirements.
PV Iso Pro	PV isolation protection	1. Remove all DC inputs then restart and reconnect to inverter one by one. 2. Identify the faulty string and check the string isolation.
Ig Leak Pro1 Ig Leak Pro2 Ig Leak Pro3 Ig Leak Pro4	Leakage current protection	1. Check AC and DC connection. 2. Check the connections inside the inverter.
Input Relay Err	Realy fault	1. Restart inverter or contact installers.
Dsp B Fault	Communication fault between main DSP and slave DSP	1. Restart inverter or contact installers.
Ig DC Err	DC component fault	1. Restart inverter or contact installers.

# 7. Troubleshooting

Alarm Message	Failure description	Solution
12V Power Err	12V power undervoltage	1. Restart System and ensure whether the fault is existing.
Leak Sensor Err	Leakage self-detection fault	1. Restart System and ensure whether the fault is existing.
Under Temp	Undertemperature protection	1. Check the environment temperature around inverter. 2. Restart System and ensure whether the fault is existing.
AFCI Check Err	Arc self-detection fault	1. Check whether there is arc in PV connection and restart inverter.
AFCI Err	Arc protection	1. Restart inverter or contact installers.
Dsp Ram Err	Abnormal SRAM of DSP board	1. Restart inverter or contact installers.
Dsp Flash Err	Abnormal FLASH of DSP board	1. Restart inverter or contact installers.
Dsp PC Err	Abnormal PC pointer of DSP board	1. Restart inverter or contact installers.
Dsp Reg Err	Abnormal key register of DSP	1. Restart inverter or contact installers.
Grid Disturb2	Grid disturbing 02	1. Restart inverter. 2. Change power board.
Ig AD Err	Abnormal sampling of Grid current	1. Restart inverter or contact installers.
Output Short Circuit	IGBT overcurrent	1. Restart inverter. 2. Change power board.
Grid Resonance	Grid resonance	1. Restart inverter or contact installers.
Trans Ov-Ig	Transient overcurrent of AC side	1. Restart inverter. 2. Return to factory for repairing.
Hw Ov-Vbatt	Battery overvoltage and firmware fault	1. Restart the battery and contact battery manufacture for handling if the fault still exists.
LLC Over Curr	LLC firmware overcurrent	1. Restart inverter. 2. Return to factory for repairing.
Batt Over Volt	Battery overvoltage detection	1. Check whether battery breaker has tripped. 2. Check whether battery is damaged. 3. Check whether battery parameter settings are reasonable.
Batt Under Volt	Battery undervoltage detection	1. Check whether battery breaker has tripped. 2. Check whether battery is damaged. 3. Check whether battery parameter settings are reasonable.
No Battery	Battery module is not connected	1. Check whether the power line of battery is connected correctly. 2. Check whether the output voltage of battery is correct.

# 7. Troubleshooting

Alarm Message	Failure description	Solution
Backup Over Volt	Bypass overvoltage fault	1. Check whether Backup port wire is normal. 2. Restart system and confirm whether the fault is existing.
Dsp SelfCk Err	Abnormal self-detection of DSP	1. Restart inverter or contact installers.
Backup Over Curr	Bypass overcurrent fault	1. Restart inverter or contact installers.
Soft Start Err	Soft start failure	1. Restart inverter. 2. Return to factory for repairing.
Nbus Earthing Err	Impedance of N-Ground fault	1. Check whether the Grounding line is connected correctly.
Pbus Earthing Err	Impedance of L-Ground fault	1. Check whether the Grounding line is connected correctly.
Eeprom Init Err	Eeprom initializing fault	1. Restart inverter or contact installers.
Bus & Batt Over Volt	Overvoltage fault of Bus and battery	1. Restart System and ensure whether the fault is existing.
Ig AD Check Err	Abnormal self-detection of Grid current	1. Restart inverter or contact installers.
BMS Over Volt	Battery overvoltage of BMS	1. Restart the battery and contact battery manufacture for handling if the fault still exists.
BMS Under Volt	Battery undervoltage of BMS	
BMS Over Temp	Battery overtemperature of BMS	
BMS Under Temp	Battery undertemperature of BMS	
BMS Dischg. Ov_C	Discharge overcurrent of BMS	
BMS Chg. Ov_C	Charge overcurrent of BMS	
BMS Internal	External fault of BMS	
BMS Imbalance	Battery unbalance of BMS	
Fail safe	CT or Meter failure	1. Confirm whether connection of meter or CT is correct.
Meter Comm Fail	Meter communication fault	1. Check whether the communication cable of meter is damaged. 2. Confirm whether DRM cable connection is reliable. 3. Check whether meter is damaged.
Can Comm Fail	Battery communication fault	1. Check whether the communication cable of meter is damaged.

# 7. Troubleshooting

Alarm Message	Failure description	Solution
Dsp Comm Fail	DSP communication fault	1. Restart DSP to ensure whether the fault is existing.
BMS Alarm	Alarm fault of BMS	1. Restart the Battery to ensure whether the fault is existing.
Batt Name Err	Uncorrespondence of battery select	1. Confirm whether the selected battery brand in inverter is consistent with the actual battery.
Heatsink Ntc Err	External temperature sensor failure	1. Check whether temperature sensor has been installed in the Lead-acid battery. 2. Check whether the NTC cable is connected to the inverter correctly. 3. Restart system and confirm whether the fault still exists.
Buck Boost Ov_C	Buckboost overcurrent	1. Restart system and confirm whether the fault still exists.
AC Reverse	AC connected reversely	1. Check the cable polarity of AC side.
Lead-acid batt UTP	Undertemperature of lead-acid battery	1. Check whether the environment temperature of Lead-acid is in the normal range.
Lead-acid batt OTP	Overttemperature of lead-acid battery	1. Check whether the environment temperature of Lead-acid is in the normal range.

Table 7.1 Fault Message and Description



**NOTE:**

If the inverter displays any alarm message as listed in Table 7.1; please turn off the inverter and wait for 5 minutes before restarting it. If the failure persists, please contact your local distributor or the service center.

Please keep ready with you the following information before contacting us.

1. Serial number of Solis Inverter;
2. The distributor/dealer of Solis Inverter (if available);
3. Installation date.
4. The description of problem (i.e. the alarm message displayed on the LCD and the status of the LED status indicator lights. Other readings obtained from the Information submenu (refer to Section 3.10) will also be helpful.);
5. The PV array configuration (e.g. number of panels, capacity of panels, number of strings, etc.);
6. Your contact details.

# 8. Specifications

Model	S6-EO1P4K-48
<b>Solar Charger</b>	
Recommended max. PV power	5.5kW
Max. input voltage	500V
Start-up voltage	90V
MPPT voltage range	90-430V
Full load MPPT voltage range	171-430V
Max. input current	16A/16A
Max. short circuit current	40A
Max. Solar Charge Current	100A
MPPT number / Max. input strings number	1/2
<b>Battery</b>	
Battery Type	Li-ion/Lead-acid
Rated battery voltage	40-60V
Max. charge / discharge power	5000W/5000W
Max. charge / discharge current	100A
Communication	CAN/RS485
<b>Inverter Output</b>	
Rated output power	4kVA/4kW
Operation phase	L/N/PE
Rated output voltage	230V±1%
Rated grid frequency	50Hz/60Hz±0.1%
Surge Capacity	8kVA
Max. Output Current	20A
Output Voltage Waveform	Pure sine wave
Transfer Time	10ms typical, 20ms Max
THDv (@linear load)	<3%
Peak Efficiency(PV-AC)	93.00%

# 8. Specifications

Model	S6-EO1P4K-48
<b>AC Charger</b>	
Rated Input Voltage	230V
Selectable Voltage Range	90-280V
AC Frequency Range	50Hz/60Hz(Auto sensing)
Max. AC Charge Current	60A
<b>Generator</b>	
Rated input power	4kW
Rated input current	60A
<b>Protection</b>	
Output Over Voltage Protection	Yes
Output Over Current Protection	Yes
Short Circuit Protection	Yes
Surge Protection	Yes
Temperature Compensation Protection	Yes
Integrated AFCI (DC arc-fault circuit protection)	Yes
<b>General Data</b>	
Dimension(W*H*D)	340*480*170mm
Net Weight	13.8kg
Relative Humidity	5% to 95% (Non-condensing)
Operation Temperature Range	-10°C-60°C
Storage Temperature Range	-25°C-60°C
Ingress Protection	IP21
Max. Operation Altitude	2000m
Parallel capability	6 units
Safety/EMC standard	IEC 62109, IEC 61000, 55011
<b>Features</b>	
DC Connection	Terminal Connectors
AC Connection	Terminal Connectors
Display	LCD
Communication Interface	CAN, BMS, RS485, Dry-contact, Bluetooth, Optional: Wifi

# 8. Specifications

Model	S6-EO1P5K-48
<b>Solar Charger</b>	
Recommended max. PV power	6.5kW
Max. input voltage	500V
Start-up voltage	90V
MPPT voltage range	90-430V
Full load MPPT voltage range	215-430V
Max. input current	16A/16A
Max. short circuit current	40A
Max. Solar Charge Current	100A
MPPT number / Max. input strings number	1/2
<b>Battery</b>	
Battery Type	Li-ion/Lead-acid
Rated battery voltage	40-60V
Max. charge / discharge power	5000W/5000W
Max. charge / discharge current	100A
Communication	CAN/RS485
<b>Inverter Output</b>	
Rated output power	5kVA/5kW
Operation phase	L/N/PE
Rated output voltage	230V±1%
Rated grid frequency	50Hz/60Hz±0.1%
Surge Capacity	10kVA
Max. Output Current	25A
Output Voltage Waveform	Pure sine wave
Transfer Time	10ms typical, 20ms Max
THDv (@linear load)	<3%
Peak Efficiency(PV-AC)	93.00%

# 8. Specifications

Model	S6-EO1P5K-48
<b>AC Charger</b>	
Rated Input Voltage	230V
Selectable Voltage Range	90-280V
AC Frequency Range	50Hz/60Hz(Auto sensing)
Max. AC Charge Current	80A
<b>Generator</b>	
Rated input power	5kW
Rated input current	80A
<b>Protection</b>	
Output Over Voltage Protection	Yes
Output Over Current Protection	Yes
Short Circuit Protection	Yes
Surge Protection	Yes
Temperature Compensation Protection	Yes
Integrated AFCI (DC arc-fault circuit protection)	Yes
<b>General Data</b>	
Dimension(W*H*D)	340*480*170mm
Net Weight	13.8kg
Relative Humidity	5% to 95% (Non-condensing)
Operation Temperature Range	-10°C-60°C
Storage Temperature Range	-25°C-60°C
Ingress Protection	IP21
Max. Operation Altitude	2000m
Parallel capability	6 units
Safety/EMC standard	IEC 62109, IEC 61000, 55011
<b>Features</b>	
DC Connection	Terminal Connectors
AC Connection	Terminal Connectors
Display	LCD
Communication Interface	CAN, BMS, RS485, Dry-contact, Bluetooth, Optional: Wifi

# 8. Specifications

Model	S6-EO1P6K-48
<b>Solar Charger</b>	
Recommended max. PV power	6.5kW
Max. input voltage	500V
Start-up voltage	90V
MPPT voltage range	90-430V
Full load MPPT voltage range	215-430V
Max. input current	16A/16A
Max. short circuit current	40A
Max. Solar Charge Current	100A
MPPT number / Max. input strings number	1/2
<b>Battery</b>	
Battery Type	Li-ion/Lead-acid
Rated battery voltage	40-60V
Max. charge / discharge power	6000W
Max. charge / discharge current	120A
Communication	CAN/RS485
<b>Inverter Output</b>	
Rated output power	6kVA/6kW
Operation phase	L/N/PE
Rated output voltage	230V±1%
Rated grid frequency	50Hz/60Hz±0.1%
Surge Capacity	12kVA
Max. Output Current	30A
Output Voltage Waveform	Pure sine wave
Transfer Time	10ms typical, 20ms Max
THDv (@linear load)	<3%
Peak Efficiency(PV-AC)	93.00%

# 8. Specifications

Model	S6-EO1P6K-48
<b>AC Charger</b>	
Rated Input Voltage	230V
Selectable Voltage Range	90-280V
AC Frequency Range	50Hz/60Hz(Auto sensing)
Max. AC Charge Current	80A
<b>Generator</b>	
Rated input power	6kW
Rated input current	80A
<b>Protection</b>	
Output Over Voltage Protection	Yes
Output Over Current Protection	Yes
Short Circuit Protection	Yes
Surge Protection	Yes
Temperature Compensation Protection	Yes
Integrated AFCI (DC arc-fault circuit protection)	Yes
<b>General Data</b>	
Dimension(W*H*D)	340*480*170mm
Net Weight	13.8kg
Relative Humidity	5% to 95% (Non-condensing)
Operation Temperature Range	-10°C-60°C
Storage Temperature Range	-25°C-60°C
Ingress Protection	IP21
Max. Operation Altitude	2000m
Parallel capability	6 units
Safety/EMC standard	IEC 62109, IEC 61000, 55011
<b>Features</b>	
DC Connection	Terminal Connectors
AC Connection	Terminal Connectors
Display	LCD
Communication Interface	CAN, BMS, RS485, Dry-contact, Bluetooth, Optional: Wifi