



MEDALPOWER

# INVERTER

**3.5KW**

***Solar Hybrid Inverter***

**MPI3.5KW#24VPVM**



[www.medal-power.com](http://www.medal-power.com)



# Table Of Contents

<b>ABOUT THIS MANUAL</b> .....	1
Purpose.....	1
Scope.....	1
<b>SAFETY INSTRUCTIONS</b> .....	1
<b>INTRODUCTION</b> .....	2
Features.....	2
Basic System Architecture.....	2
Product Overview.....	3
<b>INSTALLATION</b> .....	4
Unpacking and Inspection.....	4
Preparation.....	4
Mounting the Unit.....	4
Battery Connection.....	5
AC Input/Output Connection.....	6
PV Connection .....	8
Final Assembly.....	9
Communication Connection.....	10
Dry Contact Signal.....	10
<b>OPERATION</b> .....	11
Power ON/OFF.....	11
Operation and Display Panel.....	11
LCD Display Icons.....	12
LCD Setting.....	14
Fault Reference Code.....	20
Warning Indicator.....	21
Operating Mode Description.....	22
Display Setting.....	23
<b>SPECIFICATIONS</b> .....	24
Table 1 Line Mode Specifications.....	24
Table 2 Inverter Mode Specifications.....	25
Table 3 Charge Mode Specifications.....	26
Table 4 General Specifications.....	27
<b>TROUBLE SHOOTING</b> .....	28
<b>Appendix: Approximate Back-up Time Table</b> .....	29
<b>Wi-Fi Kit Quick Installation Guideline</b> .....	30

## ABOUT THIS MANUAL

### Purpose

This manual describes the assembly, installation, operation and troubleshooting of this unit. Please read this manual carefully before installations and operations. Keep this manual for future reference.

### Scope

This manual provides safety and installation guidelines as well as information on tools and wiring.

### The following cases are not within the scope of warranty:

- (1) Out of warranty.
- (2) Series number was changed or lost.
- (3) Battery capacity was declined or external damaged.
- (4) Inverter was damaged caused of transport shift, remissness, ect external factor.
- (5) Inverter was damaged caused of irresistible natural disasters.
- (6) Not in accordance with the electrical power supply conditions or operate environment caused damage.

## SAFETY INSTRUCTIONS



**WARNING: This chapter contains important safety and operating instructions. Read and keep this manual for future reference.**

1. Before using the unit, read all instructions and cautionary markings on the unit, the batteries and all appropriate sections of this manual.
2. **CAUTION** –To reduce risk of injury, charge only deep-cycle lead acid type rechargeable batteries. Other types of batteries may burst, causing personal injury and damage.
3. Do not disassemble the unit. Take it to a qualified service center when service or repair is required. Incorrect re-assembly may result in a risk of electric shock or fire.
4. To reduce risk of electric shock, disconnect all wirings before attempting any maintenance or cleaning. Turning off the unit will not reduce this risk.
5. **CAUTION** – Only qualified personnel can install this device with battery.
6. **NEVER** charge a frozen battery.
7. For optimum operation of this inverter/charger, please follow required spec to select appropriate cable size. It's very important to correctly operate this inverter/charger.
8. Be very cautious when working with metal tools on or around batteries. A potential risk exists to drop a tool to spark or short circuit batteries or other electrical parts and could cause an explosion.
9. Please strictly follow installation procedure when you want to disconnect AC or DC terminals. Please refer to INSTALLATION section of this manual for the details.
10. Fuses (1 piece of 200A,63VDC for 5.5KW and 2.5KW/3.0/3.5KW) are provided as over-current protection for the battery supply.
11. **GROUNDING INSTRUCTIONS** -This inverter/charger should be connected to a permanent grounded wiring system. Be sure to comply with local requirements and regulation to install this inverter.
12. **NEVER** cause AC output and DC input short circuited. Do NOT connect to the mains when DC input short circuits.
13. **Warning!!** Only qualified service persons are able to service this device. If errors still persist after following troubleshooting table, please send this inverter/charger back to local dealer or service center for maintenance.

## INTRODUCTION

This is a multi-function inverter/charger, combining functions of inverter, solar charger and battery charger to offer uninterruptible power support with portable size. Its comprehensive LCD display offers user-configurable and easy-accessible button operation such as battery charging current, AC/solar charger priority, and acceptable input voltage based on different applications.

## Features

- Pure sine wave inverter
- Configurable input voltage range for home appliances and personal computers via LCD setting
- Configurable battery charging current based on applications via LCD setting
- Configurable AC/Solar Charger priority via LCD setting
- Compatible to mains voltage or generator power
- Auto restart while AC is recovering
- Overload/ Over temperature/ short circuit protection
- Smart battery charger design for optimized battery performance
- Cold start function
- Including built-in wifi and antenna
- BMS communication
- Dual output

## Basic System Architecture

The following illustration shows basic application for this inverter/charger. It also includes following devices to have a complete running system:

- Generator or Utility.
- PV modules (option)

Consult with your system integrator for other possible system architectures depending on your requirements.

This inverter can power all kinds of appliances in home or office environment, including motor-type appliances such as tube light, fan, refrigerator and air conditioner.

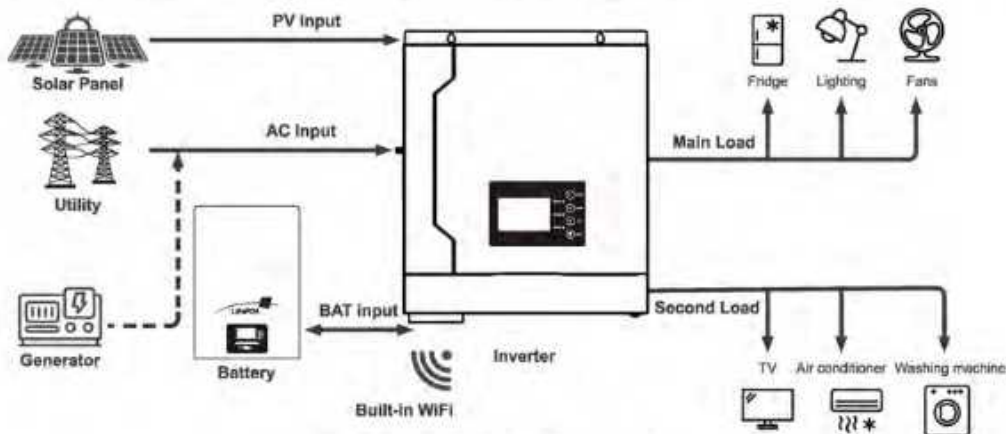
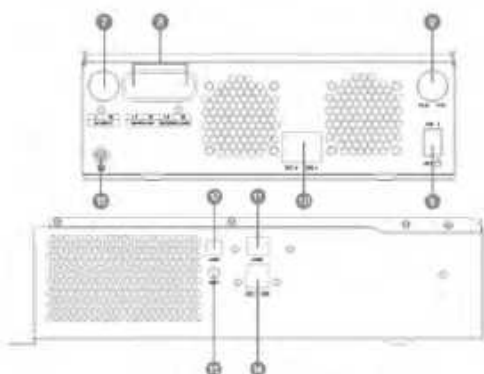
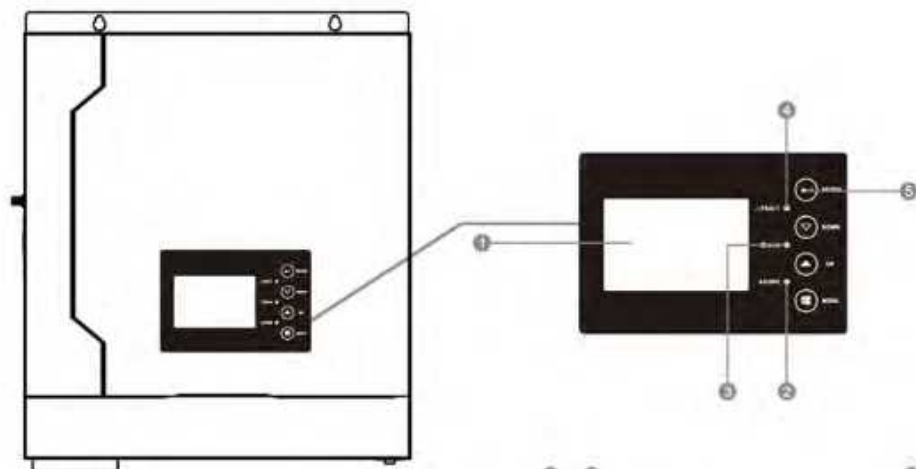
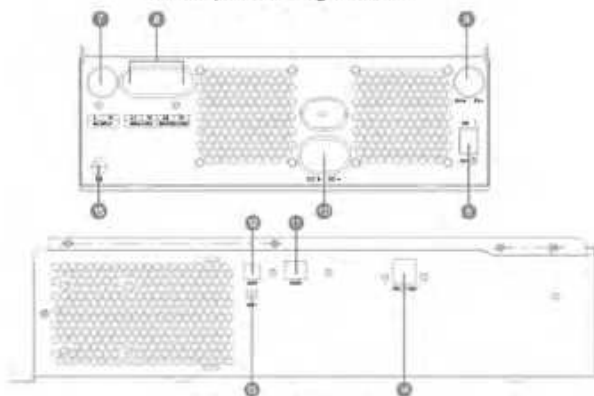

Figure 1 Hybrid Power System

## Product Overview



**2.5KW/3.0KW single model**



**5.5KW single model**

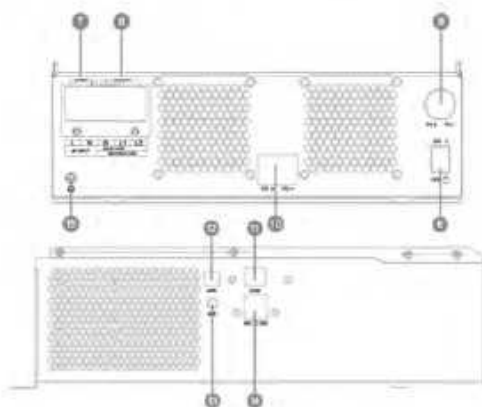

**3.5KW single model**

1. LCD display
2. Status indicator
3. Discharging/Charging indicator
4. Fault indicator
5. Function buttons
6. Power on/off switch
7. AC input
8. AC output
9. PV input
10. Battery input
11. RS-485,CAN communication port
12. USB
- 13.External WIFI antenna
- 14.Dry Contact
- 15.Ground

## INSTALLATION

### Unpacking and Inspection

Before installation, please inspect the unit. Be sure that nothing inside the package is damaged. You should have received the following items inside of package:

- The unit x 1
- User manual x 1

### Preparation

Before connecting all wirings, please take off bottom cover by removing two screws as shown below.

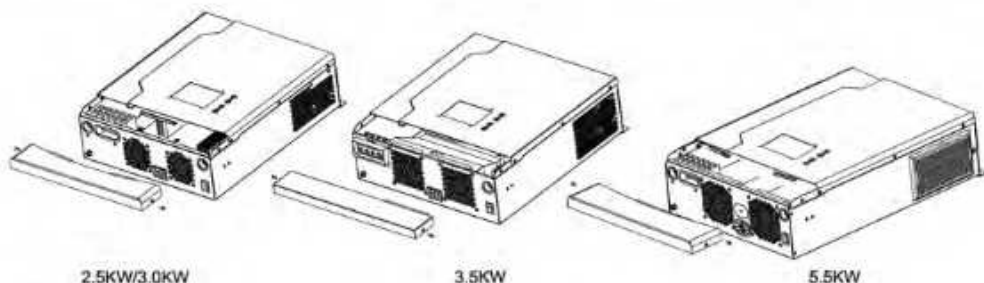

### Mounting the Unit

Consider the following points before selecting where to install:

- Do not mount the inverter on flammable construction materials.
- Mount on a solid surface
- Install this inverter at eye level in order to allow the LCD display to be read at all times.
- For proper air circulation to dissipate heat, allow a clearance of approx. 200 mm to the side and approx. 300 mm above and below the unit.
- The ambient temperature should be between  $-10^{\circ}\text{C}$  and  $50^{\circ}\text{C}$  to ensure optimal operation.
- The recommended installation position is to be adhered to the wall vertically.
- Be sure keep other objects and surfaces as shown in the below diagram to guarantee sufficient heat dissipation and to have enough space for removing wires.

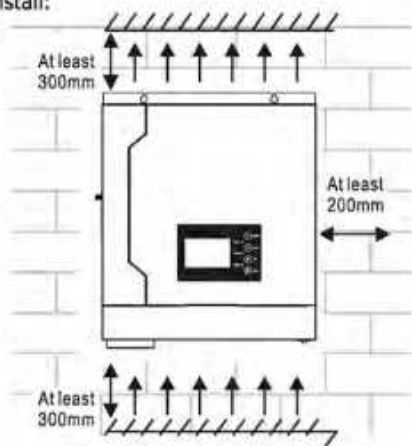

**SUITABLE FOR MOUNTING ON CONCRETE OR OTHER NON-COMBUSTIBLE SURFACE ONLY.**

Install the unit by screwing two screws.

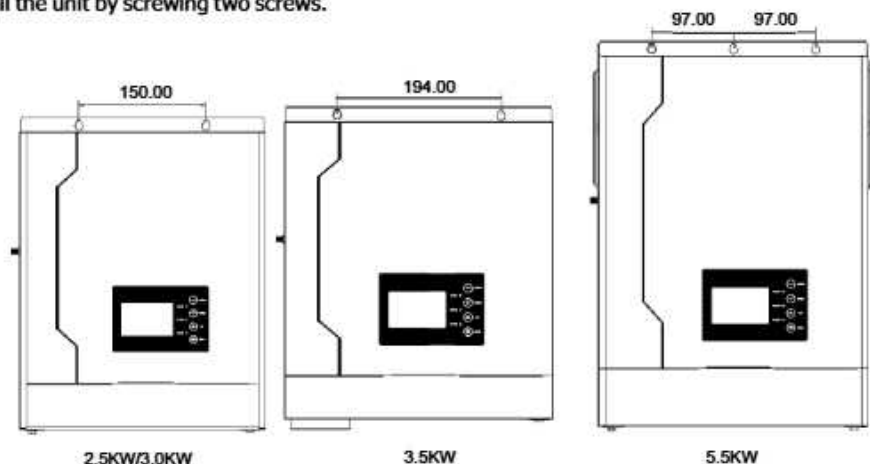

### Battery Connection

**CAUTION:** To safety operation and regulation compliance, it's requested to install a separate DC over-current protector or disconnect device between battery and inverter. It may not be requested to have a disconnect device in some applications, however, it's still requested to have over-current protection installed. Please refer to typical amperage in below table as required fuse or beaker size.

**WARNING!** All wiring must be performed by a qualified personnel.

**WARNING!** It's very important for system safety and efficient operation to use appropriate cable for battery connection. To reduce risk of injury, please use the proper recommended cable and terminal size as below.

Ring terminal:

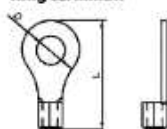

### Recommended battery cable and terminal size:

Model	Typical Amperage	Battery capacity	Wire Size
2.5KW DC24V	120A	100AH	1*4AWG
		200AH	2*6AWG
3.0KW DC24V	135A	100AH	1*4AWG
		200AH	2*6AWG
3.5KW DC24V	150A	100AH	2*4AWG
		200AH	2*4AWG
5.5KW DC48V	135A	100AH	1*4AWG
		200AH	2*6AWG

Please follow below steps to implement battery connection:

1. Assemble battery ring terminal based on recommended battery cable and terminal size.
2. 2.5KW/3.0KW/3.5KW model supports 24VDC system. Connect all battery packs as below chart, It's suggested to connect at least 100Ah capacity battery for 2.5KW/3.0KW/3.5KW model, and at least 200Ah copacity battery for 5.5KW.

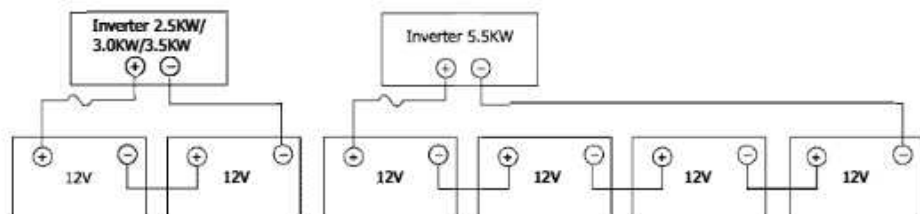

3. Insert the ring terminal of battery cable flatly into battery connector of inverter and make sure the bolts are tightened with torque of 2-3 Nm. Make sure polarity at both the battery and the inverter/charge is correctly connected and ring terminals are tightly screwed to the battery terminals.

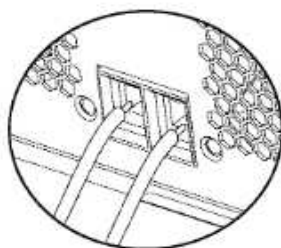

2.5KW/3.0KW/3.5KW

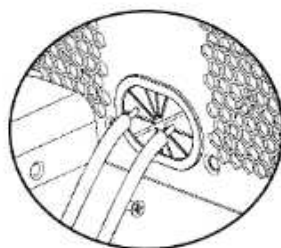

5.5KW



**WARNING: Shock Hazard**

Installation must be performed with care due to high battery voltage in series.



**CAUTION!!** Do not place anything between the flat part of the inverter terminal and the ring terminal. Otherwise, overheating may occur.

**CAUTION!!** Do not apply anti-oxidant substance on the terminals before terminals are connected tightly.

**CAUTION!!** Before making the final DC connection or closing DC breaker/disconnector, be sure DC (+) must be connected to DC (+) and DC (-) must be connected to DC (-).

**AC Input/Output Connection**

**CAUTION!!** Before connecting to AC input power source, please install a separate AC breaker between inverter and AC input power source. This will ensure the inverter can be securely disconnected during maintenance and fully protected from over current of AC input.

**CAUTION!!** There are two terminal blocks with "IN" and "OUT" markings. Please do NOT-misconnect Input and output connectors.

**WARNING!** All wiring must be performed by a qualified personnel.

**WARNING!** It's very important for system safety and efficient operation to use appropriate cable for AC input connection. To reduce risk of injury, please use the proper recommended cable size as below.

**Suggested cable requirement for AC wires**

Model	Gauge	Torque Value
2.5KW/3.0KW/3.5KW	12AWG	1.2~1.6Nm
5.5KW	8AWG	1.4~1.6Nm

Please follow below steps to implement AC input/output connection:

1. Before making AC input/output connection, be sure to open DC protector or disconnecter first.
2. Remove insulation sleeve 10mm for six conductors. And shorten phase L and neutral conductor N 3 mm.
3. Insert AC input wires according to polarities indicated on terminal block and tighten the terminal screws. Be sure to connect PE protective conductor (⊕) first.

⊕ → **Ground (yellow-green)**

L → **LINE (brown or black)**

N → **Neutral (blue)**

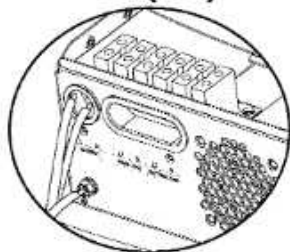

2.5KW/3.0KW

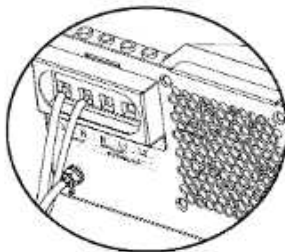

3.5KW

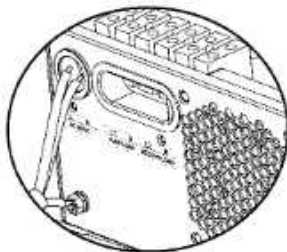

5.5KW



**WARNING:**

Be sure to that AC power source is disconnected before attempting to hardwire it to the unit.

4. Then, insert AC output wires according to polarities indicated on terminal block and tighten terminal screws. Be sure to connect PE protective conductor (⊕) first.

⊕ → **Ground (yellow-green)**

L1 → **LINE (brown or black)**

L2 → **LINE (brown or black)**

N → **Neutral (blue)**

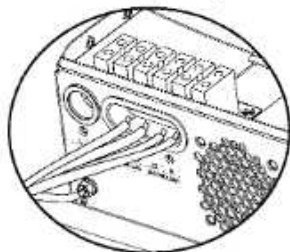

2.5KW/3.0KW

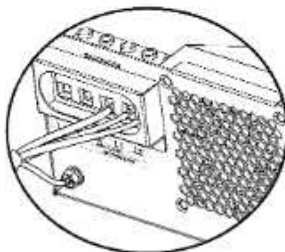

3.5KW

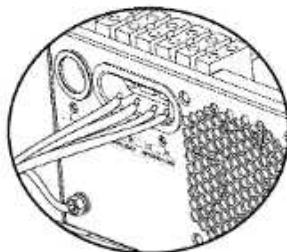

5.5KW

5. Make sure the wires are securely connected.

**CAUTION: Important**

Be sure to connect AC wires with correct polarity. If L and N wires are connected reversely, it may cause utility short-circuited when these inverters are working in parallel operation.

**CAUTION:** Appliances such as air conditioner are required at least 2~3 minutes to restart because it's required to have enough time to balance refrigerant gas inside of circuits. If a power shortage occurs and recovers in a short time, it will cause damage to your connected appliances. To prevent this kind of damage, please check manufacturer of air conditioner if it's equipped with time-delay function before installation. Otherwise, this inverter/charger will trig overload fault and cut off output to protect your appliance but sometimes it still causes internal damage to the air conditioner.

**PV Connection**

**CAUTION:** Before connecting to PV modules, please install separately a DC circuit breaker between inverter and PV modules.

**WARNING!** All wiring must be performed by a qualified personnel.

**WARNING!** It's very important for system safety and efficient operation to use appropriate cable for PV module connection. To reduce risk of injury, please use the proper recommended cable size as below.

Model	Typical Amperage	Cable Size	Torque
2.5KW/3.0KW/3.5KW	18A	12AWG	1.2~1.6Nm
5.5KW	28A	10AWG	

**PV Module Selection:**

When selecting proper PV modules, please be sure to consider below parameters:

1. Open circuit Voltage (Voc) of PV modules not exceeds max. PV array open circuit voltage of inverter.
2. Open circuit Voltage (Voc) of PV modules should be higher than min. battery voltage.
3. Max. Power Voltage (Vmpp) of PV modules should be close to best Vmp of inverter or within Vmp range to get best performance. If one PV module can not meet this requirement, it's necessary to have several PV modules in series connection. Refer to below table.

**Note:**\* Vmp: panel max power point voltage.

The PV charging efficiency is maximized while PV system voltage is close to Best Vmp.

**Maximum PV module numbers in Series:** Vmpp of PV module\*X pcs = Best Vmp of Inverter or Vmp range

**PV module numbers in Parallel:** Max. charging current of inverter/Imp

**Total PV module numbers=maximum PV module numbers in series\*PV module numbers in parallel**

Solar Charging Mode			
INVERTER MODEL	MPPT charger		
	2.5KW/3.0KW	3.5KW	5.5KW
Charging Current	100A		
Max. PV Array Open Circuit Voltage	400Vdc	450Vdc	
PV Array MPPT Voltage Range	30~320Vdc	60~360Vdc	
System DC voltage	24Vdc		48Vdc

Please follow below steps to implement PV module connection:

1. Remove insulation sleeve 10 mm for positive and negative conductors.
2. Check correct polarity of connection cable from PV modules and PV input connectors. Then, connect positive pole (+) of connection cable to positive pole (+) of PV input connector. Connect negative pole (-) of connection cable to negative pole (-) of PV input connector.

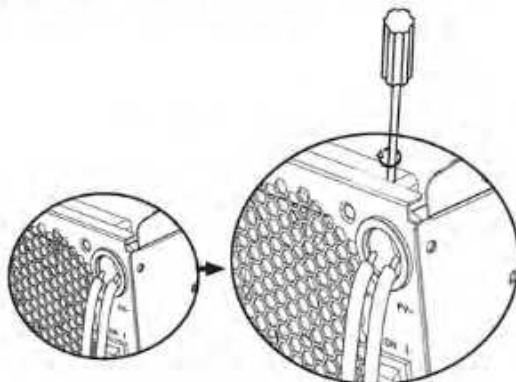

3. Make sure the wires are securely connected.

#### Recommended PV module configuration

PV Module Spec (reference)	Total solar input power	Solar input	Q'ty of modules
Maximum Power (Pmax): 425W	2550W	6 pieces in series	6 pcs
Max. Power Voltage Vmpp(V) :38.6V	3400W	8 pieces in series	8 pcs
Max. Power Current Imp(A) :11.02A	5100W	6pieces in series 2 strings in parallel	12 pcs
Open Circuit Voltage Voc(V) :45.80V	5950W	7pieces in series 2 strings in parallel	14 pcs
Short Circuit Current Isc(A) :11.81A			

#### Final Assembly

After connecting all wirings, please put bottom cover back by screwing two screws as shown below.



2.5KW/3.0KW

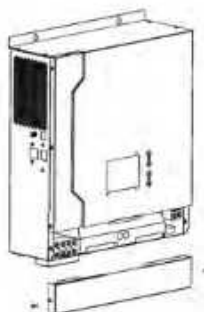

3.5KW

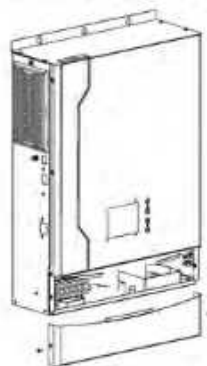

5.5KW

## Communication Connection

Please use supplied communication cable to inverter and PC. Download the software by link on the last page of this manual into computer and follow on screen instruction to install the monitoring software. For the detailed software operation, please consult the seller if you have any questions.

**CAUTION:** Only the CAN prot can be used to communicate with the smart battery pack. You need to use CAN-L, CAN-H and GND to establish a connection.

**WARNING:** It's forbidden to use network cable as the communication cable to directly communicate with the PC port. Otherwise, the internal components of the controller will be damaged.

**WARNING:** RJ45 interface is only suitable for the use of the company's supporting products or professional operation.

Below chart shows RJ45 Pins definition

Pin	Definition
1	RS-485-B
2	RS-485-A
3	GND
4	CAN-H
5	CAN-L
6	GND
7	
8	

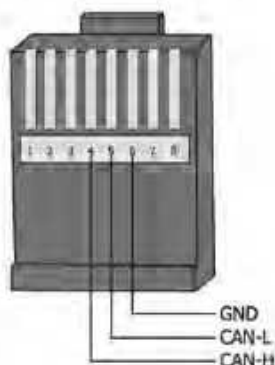

## Dry Contact Signal

There is one dry contact (3A/250VAC) available on the rear panel. It could be used to deliver signal to external device when battery voltage reaches warning level.

Unit status	Condition		Dry contact port:		
			NC&C	NO&C	
Power Off	Unit is off and no output is powered.		Close	Open	
	output is powered from Utility		Close	Open	
Power On	Output is powered from Battery or Solar.	Program 37=VOL	Battery voltage<Low DC warning voltage(IF program 01 is set as SBU or SOL, low DC warning voltage= setting value in Program 21)	Open	Close
			Battery voltage>Setting value in Program 21	Close	Open
		Program 37=SOC (BMS communication is established)	SOC of Lithium battery<5%+ Setting value in Program 38	Open	Close
			SOC of Lithium battery>35%+ Setting value in Program 38	Close	Open

## OPERATION

### Power ON/OFF

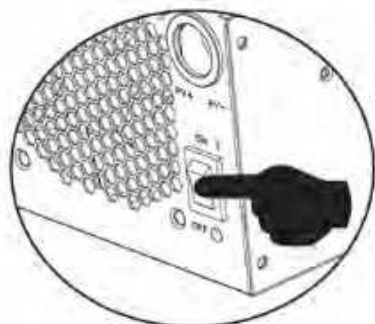

Once the unit has been properly installed and the batteries are connected well, simply press On/Off switch (located on the button of the case) to turn on the unit.

### Operation and Display Panel

The operation and display panel, shown in below chart, is on the front panel of the inverter. It includes three indicators, four function keys and a LCD display, indicating the operating status and input/output power information.



### LED Indicator

LED Indicator		Messages	
AC/INV	Green	Solid On	Output is powered by grid in Line mode.
		Flashing	Output is powered by battery or PV in battery mode.
● CHG	Yellow	Flashing	Battery is charging or discharging.
△ FAULT	Red	Solid On	Fault occurs in the inverter.
		Flashing	Warning condition occurs in the inverter.

### Function Keys

Function Keys	Description
MENU	Enter reset mode or setting mode go to previous selection.
UP	Increase the setting data.
DOWN	Decrease the setting data.
ENTER	Enter setting mode and Confirm the selection in setting mode go to next selection or exit the reset mode.

## LCD Display Icons

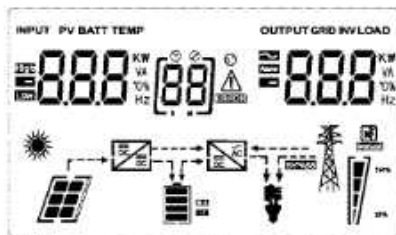

Icon	Function description	
<b>Input Source Information and Output Information</b>		
	Indicates the AC information.	
	Indicates the DC information.	
	Indicate input voltage, input frequency, PV voltage, battery voltage and charger current. Indicate output voltage, output frequency, load in VA, load in Watt and discharging current.	
<b>Configuration Program and Fault Information</b>		
	Indicates the setting programs.	
	Indicates the warning and fault codes. Warning: flashing  with warning code. Fault: lighting  with fault code.	
<b>Battery Information</b>		
	Indicates battery level by 0-24%, 25-49%, 50-74% and 75-100% in battery mode and charging status in line mode.	
In AC mode, it will present battery charging status.		
Status	Battery voltage	LCD Display
Constant	<2V/cell	4 bars will flash in turns.
Current mode / Constant	2 ~ 2.083V/cell	Bottom bar will be on and the other three bars will flash in turns.
Voltage mode	2.083 ~ 2.167V/cell	Bottom two bars will be on and the other two bars will flash in turns.
	> 2.167 V/cell	Bottom three bars will be on and the top bar will flash.
Batteries are fully charged.		4 bars will be on.

In battery mode, it will present battery capacity.				
Load Percentage	Battery Voltage	LCD Display		
Load >50%	< 1.717V/cell			
	1.717V/cell ~ 1.8V/cell			
	1.8 ~ 1.883V/cell			
	> 1.883 V/cell			
50% > Load > 20%	< 1.817V/cell			
	1.817V/cell ~ 1.9V/cell			
	1.9 ~ 1.983V/cell			
	> 1.983V/cell			
Load < 20%	< 1.867V/cell			
	1.867V/cell ~ 1.95V/cell			
	1.95 ~ 2.033V/cell			
	> 2.033V/cell			
<b>Load Information</b>				
	Indicates overload.			
	Indicates the load level by 0-24%, 25-49%, 50-74% and 75-100%.			
	0%~24%	25%~49%	50%~74%	75%~100%
<b>Mode Operation Information</b>				
	Indicates unit connected to the mains.			
	Indicates unit connected to the PV panel.			
	Indicates load is supplied by utility power.			
	Indicates the solar charger is working.			
	Indicates the DC/AC inverter circuit is working.			
<b>Mute Operation</b>				
	Indicates unit alarm is disabled.			

## LCD Setting

After pressing and holding "ENTER" button for 2 seconds, the unit will enter setting mode. Press "UP" or "DOWN" button to select setting programs. And then, press "ENTER" or "MENU" button to confirm the selection and exit.

### Setting Programs:

Program	Description	Selectable option
00	Exit setting mode	Escape [00] ESC
01	Output source priority selection	[01] SBU Solar energy provides power to the loads as first priority. If battery voltage has been higher than the setting point in program 21 for 5 minutes, the inverter will turn to battery mode, solar and battery will provide power to the load at the same time. When the battery voltage drops to the setting point in program 20, the inverter will turn to bypass mode, utility provides power to the load only, and the solar will charge the battery at the same time.
		[01] SOL Solar energy provides power to the loads as first priority. If battery voltage has been higher than the setting point in program 21 for 5 minutes, and the solar energy has been available for 5 minutes too, the inverter will turn to battery mode, solar and battery will provide power to the load at the same time. When the battery voltage drops to the setting point in program 20, the inverter will turn to bypass mode, utility provides power to the load only, and the solar will charge the battery at the same time.
		(default) [01] UT, Utility will provide power to the loads as first priority. Solar and battery energy will provide power to the loads only when utility power is not available.

02	AC input voltage range	Appliances (default) [02] RPL	If selected, acceptable AC input voltage range will be within 90-280VAC.
		UPS [02] UPS	If selected, acceptable AC input voltage range will be within 170-280VAC.
		VDE [02] VDE	If selected, acceptable AC input voltage range will conform to VDE4105(184VAC-253VAC).
		GEN [02] GEN	When the user uses the device to connect the generator, select the generator mode.
03	Output voltage	[03] 230 <sup>v</sup>	Set the output voltage amplitude, (220VAC-240VAC).
04	Output frequency	50HZ(default) [04] 500	60HZ [04] 600
05	Solar supply priority	[05] BLU	Solar energy provides power to charge battery as first priority.
		(default) [05] LBU	Solar energy provides power to the loads as first priority.
06	Overload bypass: When enabled, the unit will transfer to line mode if overload occurs in battery mode.	Bypass disable [06] BYD	Bypass enable (default) [06] BYE
07	Auto restart when overload occurs	Restart disable (default) [07] LTD	Restart enable [07] LTE
08	Auto restart when over temperature occurs	Restart disable (default) [08] LTD	Restart enable [08] LTE
10	Charger source priority: To configure charger source priority	If this inverter/charger is working in Line, Standby or Fault mode, charger source can be programmed as below:	
		Solar first [10] CSO	Solar energy will charge battery as first priority. Utility will charge battery only when solar energy is not available.
		Solar and Utility (default) [10] SNU	Solar energy and utility will charge battery at the same time.

		Only Solar [10] 050	Solar energy will be the only charger source no matter utility is available or not.
		If this inverter/charger is working in Battery mode or Power saving mode, only solar energy can charge battery. Solar energy will charge battery if it's available and sufficient.	
11	Maximum solar charging current (Max. charging current=utility charging current +solar charging current)	2.5KW/3.0KW/3.5KW/5.5KW 100A (default) [11] 100 A	Setting range is from 1 A to 100A. Increment of each click is 1A.
13	Maximum utility charging current (Max. charging current= utility charging current + solar charging current)	2.5KW/3.0KW/3.5KW 30A (default)	60A(Maximum current) Setting range is from 1 A to 60A. Increment of each click is 1A.
		[13] 30 A	
		5.5KW 60A (default)	100A(Maximum current) Setting range is from 1 A to 100A. Increment of each click is 1A.
		[13] 60 A	
14	Battery type	AGM (default)	Flooded
		[14] AGM	[14] FLd
		GEL	LEAD
		[14] GEL	[14] LEA
		Lithium Ion	User-Defined
		[14] LI	[14] USE
		If "User-Defined" LI is selected, battery charge voltage and low DC cut-off voltage can be set up in program 17, 18 and 19.Low DC warning voltage can be set up in program 20.	
17	Bulk charging voltage (C.V voltage)	24V model default setting: 28.2V [17] CV 28.2 V	
		If "User-Defined" LI is selected in program 14, this program can be set up. Setting range is from 24.0V to 29.2V. Increment of each click is 0.1V.	
		48V model default setting: 56.4V [17] CV 56.4 V	
		If "User-Defined" LI is selected in program 14, this program can be set up. Setting range is from 48.0V to 58.4V for 48Vdc model. Increment of each click is 0.1V.	
18	Floating charging voltage	24V model default setting: 27.0V [18] FLV 27.0 V	
		If "User-Defined" LI is selected in program 14, this program can be set up, Setting range is from 24.0V to 29.2V. Increment of each click is 0.1V.	

		<p>48V model default setting: 54.0V</p> <p>[18] FLY 54.0V</p> <p>If "User-Defined" LI is selected in program 14, this program can be set up. Setting range is from 48.0V to 58.4V for 48Vdc model. Increment of each click is 0.1V.</p>
19	Low DC cut off battery voltage or SOC setting	<p>24V model default setting: 20.4V</p> <p>[19] COV 20.4V</p> <p>If "User-Defined" LI is selected in program 14, this program can be set up. Setting range is from 20.0V to 24.0V. Increment of each click is 0.1V. Low DC cut-off voltage will be fixed to setting value no matter what percentage of load is connected.</p>
		<p>48V model default setting: 40.8V</p> <p>[19] COV 40.8V</p> <p>If "User-Defined" LI is selected in program 14, this program can be set up. Setting range is from 40.0V to 48.0V for 48Vdc model. Increment of each click is 0.1V. Low DC cut-off voltage will be fixed to setting value no matter what percentage of load is connected.</p>
		<p>SOC 10% (default)</p> <p>SOC [19] 10 %</p>
		<p>If "User-Defined" "LI" is selected in program 14, and the SOC percentage method is selected in program 37, the low DC cut-off SOC percentage will be able to be set. Setting range is from 0%-90%. Increment of each click is 1%</p>
		<p>Low DC cut-off voltage/SOC percentage will be fixed to setting value no matter what percentage of load is connected</p>
20	Low DC warning and battery stop discharging voltage when grid is available	<p>Available options for 24V models:</p> <p>23V (default)</p> <p>[20] 23.0V</p> <p>Setting range is from 22.0V to 29.0V. Increment of each click is 0.1V. If "User-Defined" LI is selected in program 14, this program can be set up. Low DC warning voltage will be fixed to setting value.</p>
		<p>Available options for 48V models:</p> <p>46.0V (default)</p> <p>[20] 46.0V</p> <p>Setting range is from 44.0V to 58.0V. Increment of each click is 0.1V. If "User-Defined" LI is selected in program 14, this program can be set up. Low DC warning voltage will be fixed to setting value.</p>
21	Low DC warning recover and battery stop charging voltage when grid is available	<p>Available options for 24V models:</p> <p>26.4V (default)</p> <p>[21] 26.4V</p> <p>Setting range is from 22.0V to 29.0V. Increment of each click is 0.1V. Low DC warning recover voltage will be fixed to setting value no matter what kind of battery type was selected.</p>

		Available options for 48V models:	
		54.0V (default) [2] 540	Setting range is from 44.0V to 58.0V. Increment of each click is 0.1V. Low DC warning recover voltage will be fixed to setting value no matter what kind of battery type was selected.
22	Auto turn page	(default) [22] PLE	If selected, the display screen will auto turn the display page.
		[22] Pld	If selected, the display screen will stay at latest screen user finally switches.
23	Backlight control	Backlight on [23] LON	Backlight off (default) [23] LOF
		Alarm on (default) [24] bON	Alarm off [24] bOF
25	Beeps while primary source is interrupted	Alarm on [25] RON	Alarm off (default) [25] ROF
		Record enable (default) [27] FON	Record disable [27] FOF
28	Solar power balance: When enabled, solar input power will be automatically adjusted according to connected load power.	Solar power balance enable [28] S6E	If selected, the solar input power will be automatically adjusted according to the following formula: Max. Input solar power = Max. battery charging power + Connected load power when the machine in OffGrid workstate.
		Solar power balance disable (default) [28] S6d	If selected, the solar input power will be the same to max. Battery charging power no matter how much loads are connected. The max. battery charging power will be based on the setting current in program 11 ( Max. solar power = Max. battery charging power ).
30	Battery equalization	Battery equalization [30] EEN	Battery equalization disable (default) [30] EdS
		Available options for 24V models:	
31	Battery equalization voltage	default setting: 28.8V [3] E4	288
		Setting range is from 24.0V to 29.2V. Increment of each click is 0.1V.	













		Available options for 48V models: [3]E <sup>4</sup> 576 <sup>v</sup>	
		Setting range is from 48.0V to 58.4V. Increment of each click is 0.1V.	
33	Battery equalization time	60min(default) [33] 60	Setting range is from 5 min to 900min. Increment of each click is 5min.
34	Battery equalization timeout	120min(default) [34] 120	Setting range is from 5 min to 900min. Increment of each click is 5min.
35	Equalization interval	30days(default) [35] 30d	Setting range is from 0 to 90days. Increment of each click is 1 day.
36	Equalization activated immediately	Enable [36] REN	Disable(default) [36] Rds
		If equalization function is enabled in program 30, this program can be set up. If "Enable" is selected in this program, it's to activate battery equalization immediately and LCD main page will shows "EQ". If "Disable" is selected, it will cancel equalization function until next activated equalization time arrives based on program 35 setting. At this time, "EQ" will be shown in LCD main page too.	
37	BMS control method	Voltage method(default) [37] 40L	SOC Percent method [37] 50C
38	SBU mode: Battery stop discharging percent When SOC is available	20 % (default) [38] 20 %	Setting range is from 5% to 95% Increment of each click is 1%.
39	SBU mode: Battery stop charging percent When SOC is available	95 % (default) [39] 95 %	Setting range is from 10% to 100% Increment of each click is 1%.
40	BMS communication	(default) [40] 1dP	when the communication between BMS and converter is faulted ,the converter still charge or discharge from the battery
		[40] 0n1	when the communication between BMS and converter is faulted ,the converter stop charging or discharging from the battery
41	Lithium battery protocol	SEL[40] 0	Setting range is from 0 to 31 Increment of each click is 1
		If LI is selected in program 14, program 41 can be set. After the program 41 is set, please restart the inverter to take effect. For example, if you set the program 41 to 0, the inverter can communicate with the Power Solid lithium battery.	
59	Dual output enable/disable	disable [59] 5ds	If disable, the second load will follow the main load.
		(default) enable [59] 5EN	If enable, the program 60 will work.



















60	Cut the second load made (Program 37 settings VOL or SOC )	24V model: 22.0V (default) 40L 22.0 V	Setting range is from 22.0V to 29.0V. Increment of each click is 0.1V.
		48V model: 44.0V (default) 40L 44.0 V	Setting range is from 44.0V to 58.0V. Increment of each click is 0.1V.
		25 % (default) 50C 25 %	Setting range is from 10% to 100% Increment of each click is 1%.

After pressing and holding "MENU" button for 6 seconds, the unit will enter reset model. Press "Up" and "DOWN" button to select programs. And then ,press "ENTER" button to exit.



SEt	(default) [dt] n7t	Reset setting disable.
	[dt] 75t	Reset setting enable.







#### Fault Reference Code

Fault Code	Fault Event	Icon on
01	Fan is locked when inverter is off	01 
02	Inverter transformer over temperature	02 
03	Battery voltage is too high or AC input L/N wires are reversed	03 
04	Battery voltage is too low	04 
05	Output short circuited	05 
06	Inverter output voltage is high	06 
07	Overload time out	07 
08	Inverter bus voltage is too high	08 
09	Bus soft start failed	09 
11	Main relay failed	11 
21	Inverter output voltage sensor error	21 
22	Inverter grid voltage sensor error	22 



23	Inverter output current sensor error	<b>23</b> 
24	Inverter grid current sensor error	<b>24</b> 
25	Inverter load current sensor error	<b>25</b> 
26	Inverter grid over current error	<b>26</b> 
27	Inverter radiator over temperature	<b>27</b> 
31	Solar charger battery voltage class error	<b>31</b> 
32	Solar charger current sensor error	<b>32</b> 
33	Solar charger current is uncontrollable	<b>33</b> 
41	Inverter grid voltage is low	<b>41</b> 
42	Inverter grid voltage is high	<b>42</b> 
43	Inverter grid under frequency	<b>43</b> 
44	Inverter grid over frequency	<b>44</b> 
51	Inverter over current protection error	<b>51</b> 
52	Inverter bus voltage is too low or component temperature is too high	<b>52</b> 
53	Inverter soft start failed	<b>53</b> 
55	Over DC voltage in AC output	<b>55</b> 
56	Battery connection is open	<b>56</b> 
57	Inverter control current sensor error	<b>57</b> 
58	Inverter output voltage is too low or component temperature is too high	<b>58</b> 

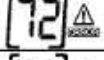

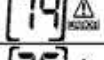
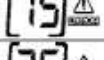
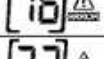
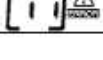
#### Warning Indicator

Fault Code	Fault Event	Icon on
61	Fan is locked when inverter is on.	<b>61</b> 
62	Fan 2 is locked when inverter is on.	<b>62</b> 

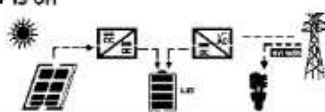
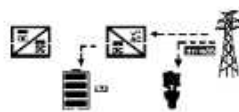
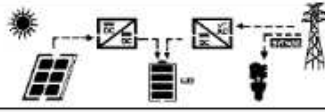
63	Battery is over-charged.	
64	Low battery.	
67	Overload.	
70	Output power derating.	
72	Solar charger stops due to low battery.	
73	Solar charger stops due to high PV voltage.	
74	Solar charger stops due to over load.	
75	Solar charger over temperature.	
76	PV charger communication error.	
77	Parameter error.	

### Operating State Description

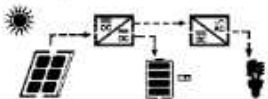
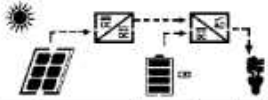
Operation state	Description	LCD display
Utility-Tie state	PV energy is charger into the battery and utility provide power to the AC load.	PV is on 
		PV is off 
Charge state	PV energy and grid can charge batteries.	
Bypass state	Error are caused by inside circuit error or external reasons such as over temperature, and so on.	

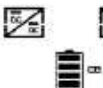
Off-Grid state	The inverter will provide output power from battery and PV power.	Inverter power loads from PV energy 
		Inverter power loads from battery and PV energy 
		Inverter power loads from battery only 
Stop mode	The inverter stop working if you turn off the inverter by the soft key or error has occurred in the condition of no grid.	

### Display Setting

The LCD display information will be switched in turns by pressing "UP" or "DOWN" key. The selectable information is switched as below order: battery voltage, battery current ,inverter voltage, inverter current, grid voltage, grid current, load in Watt, load in VA, grid frequency, inverter frequency, PV voltage, PV charging power, PV charging output voltage, PV charging current.

Selectable information	LCD display	
Battery voltage/DC discharging current	$26.0^{\text{V}}$	$48.0^{\text{A}}$
Inverter output voltage/Inverter output current	$229^{\text{V}}$	$6.70^{\text{A}}$
Grid voltage/Grid current	$229^{\text{V}}$	$-3.0^{\text{A}}$
Load in Watt/VA	$150^{\text{KW}}$	$168^{\text{KVA}}$
Grid frequency/Inverter frequency	$50.0^{\text{Hz}}$	$50.0^{\text{Hz}}$
PV voltage and power	$61.0^{\text{V}}$	$100^{\text{KW}}$
PV charger output voltage and MPPT charging current	$25.0^{\text{V}}$	$4.00^{\text{A}}$

## SPECIFICATIONS

Table 1 Line Mode Specifications

INVERTER MODEL	2.5KW/3.0KW/3.5KW DC24V	5.5KW DC48V
<b>Input Voltage Waveform</b>	Sinusoidal (utility or generator)	
<b>Nominal Input Voltage</b>	230Vac	
<b>Low Loss Voltage</b>	90Vac±7V(APL,GEN); 170Vac±7V(UPS) 186Vac±7V(VDE)	
<b>Low Loss Return Voltage</b>	100Vac±7V(APL,GEN);180Vac±7V(UPS) 196Vac±7V(VDE)	
<b>High Loss Voltage</b>	280Vac±7V(APL, UPS,GEN) 253Vac±7V(VDE)	
<b>High Loss Return Voltage</b>	270Vac±7V(APL,UPS,GEN) 250Vac±7V(VDE)	
<b>Max AC Input Voltage</b>	300Vac	
<b>Nominal Input Frequency</b>	50Hz / 60Hz (Auto detection)	
<b>Low Loss Frequency</b>	40Hz±1Hz(APL,UPS,GEN) 47.5Hz±0.05HZ(VDE)	
<b>Low Loss Return Frequency</b>	42Hz±1Hz(APL,UPS,GEN) 47.5Hz±0.05HZ(VDE)	
<b>High Loss Frequency</b>	65Hz±1Hz(APL,UPS,GEN) 51.5Hz±0.05HZ(VDE)	
<b>High Loss Return Frequency</b>	63Hz±1Hz(APL,UPS,GEN) 50.05Hz±0.05Hz(VDE)	
<b>Output Short Circuit Protection</b>	Line mode: Circuit Breaker Battery mode: Electronic Circuits	
<b>Efficiency (Line Mode)</b>	>95% ( Rated R load, battery full charged )	
<b>Transfer Time</b>	10ms typical (UPS,VDE) 20ms typical (APL)	
<p><b>Output power derating:</b> When AC input voltage drops to 170V depending on models, the output power will be derated</p>	<p>230Vac model:</p> <p>The graph plots Output Power against AC Input Voltage for a 230Vac model. The x-axis has markers at 90V, 170V, and 280V. The y-axis has markers for 50% Power and Rated Power. A horizontal dashed line at Rated Power extends from the y-axis to 170V. From 170V, a solid line slopes down to 90V, where it meets a horizontal dashed line at 50% Power. From 90V, the power drops to zero. From 170V to 280V, the output power remains constant at the Rated Power level.</p>	

Table 2 Inverter Mode Specifications

<b>INVERTER MODEL</b>	<b>2.5KW DC24V</b>	<b>3.0KW DC24V</b>	<b>3.5KW DC24V</b>	<b>5.5KW DC48V</b>
<b>Rated Output Power</b>	2500W	3000W	3500W	5500W
<b>Output Voltage Waveform</b>	Pure Sine Wave			
<b>Output Voltage Regulation</b>	230Vac±5%			
<b>Output Frequency</b>	60Hz or 50Hz			
<b>Peak Efficiency</b>	92%			
<b>Overload Protection</b>	1s@≥150% load;10s@105%~150% load			
<b>Nominal DC Input Voltage</b>	24Vdc			48Vdc
<b>Cold Start Voltage</b>	23.0Vdc			46.0Vdc
<b>Low DC Warning Voltage</b>				
@ load < 20%	22.0Vdc			44.0Vdc
@ 20% ≤ load < 50%	21.4Vdc			42.8Vdc
@ load ≥ 50%	20.2Vdc			40.4Vdc
<b>Low DC Warning Return Voltage</b>				
@ load < 20%	23.0Vdc			46.0Vdc
@ 20% ≤ load < 50%	22.4Vdc			44.8Vdc
@ load ≥ 50%	21.2Vdc			42.4Vdc
<b>Low DC Cut-off Voltage</b>				
@ load < 20%	21.0Vdc			42.0Vdc
@ 20% ≤ load < 50%	20.4Vdc			40.8Vdc
@ load ≥ 50%	19.2Vdc			38.4Vdc
<b>High DC Recovery Voltage</b>	29Vdc			58Vdc
<b>High DC Cut-off Voltage</b>	30Vdc			60Vdc

Table 3 Charge Mode Specifications

<b>Utility Charging Mode</b>					
<b>INVERTER MODEL</b>		<b>2.5KW DC24V</b>	<b>3.0KW DC24V</b>	<b>3.5KW DC24V</b>	<b>5.5KW DC48V</b>
<b>Charging Current @Nominal Input Voltage</b>		60A(± 4A)			100A(± 4A)
<b>Floating charging voltage</b>	<b>AGM / Gel/LEAD Battery</b>	27.4Vdc			54.8Vdc
	<b>Flooded Battery</b>	27.4Vdc			54.8Vdc
<b>Bulk charging voltage (C.V voltage)</b>	<b>AGM / Gel/LEAD Battery</b>	28.8Vdc			57.6Vdc
	<b>Flooded Battery</b>	28.4Vdc			56.8Vdc
<b>Charging Algorithm</b>		3-Step(Flooded Battery, AGM/Gel Battery), 4-Step(LI)			
<b>Solar Charging Mode</b>					
<b>INVERTER MODEL</b>		<b>2.5KW DC24V</b>	<b>3.0KW DC24V</b>	<b>3.5KW DC24V</b>	<b>5.5KW DC48V</b>
<b>Charging Current</b>		MPPT-100A (±4A)			MPPT-100A (±4A)
<b>System DC Voltage</b>		24Vdc			48Vdc
<b>Normal Operating Voltage Range</b>		30-320Vdc		60-360Vdc	
<b>Max.PV Array Open Circuit Voltage</b>		400Vdc		450Vdc	
<b>Standby Power Consumption</b>		2W			
<b>Battery Voltage Accuracy</b>		+/-0.3%			
<b>PV Voltage Accuracy</b>		+/-2.5V			
<b>Charging Algorithm</b>		3-Step(Flooded Battery, AGM/Gel Battery),4-Step(LI)			
<b>Charging algorithm for lead acid battery</b>					

<p><b>Charging algorithm for Lithium battery</b></p>				
<p><b>Joint Utility and Solar Charging</b></p>				
<p><b>INVERTER MODEL</b></p>	<p><b>2.5KW DC24V</b></p>	<p><b>3.0KW DC24V</b></p>	<p><b>3.5KW DC24V</b></p>	<p><b>5.5KW DC48V</b></p>
<p><b>CHARGER MODEL</b></p>	<p>MPPT-100A (±4A)</p>			<p>MPPT-100A (±4A)</p>
<p><b>Max Charging Current</b></p>	<p>100A(±4A) (GRID:60A max)</p>			<p>100A(±4A) (GRID:100A max)</p>
<p><b>Default Charging Current</b></p>	<p>100A(±4A)</p>			<p>100A(±4A)</p>

Table 4 General Specifications

<p><b>INVERTER MODEL</b></p>	<p><b>2.5KW DC24V</b></p>	<p><b>3.0KW DC24V</b></p>	<p><b>3.5KW DC24V</b></p>	<p><b>5.5KW DC48V</b></p>
<p><b>Safety Certification</b></p>	<p>CE</p>			
<p><b>Operating Temperature Range</b></p>	<p>-10°C to 50°C</p>			
<p><b>Storage temperature</b></p>	<p>-15°C~ 60°C</p>			
<p><b>Dimension (D*W*H), mm</b></p>	<p>167x291x111</p>	<p>367.5x318x121</p>	<p>436x330x122</p>	
<p><b>Net Weight, kg</b></p>	<p>6.6</p>	<p>7.1</p>	<p>9.0</p>	

## TROUBLE SHOOTING

Problem	LCD/LED/Buzzer	Explanation/Possible cause	What to do
Unit shuts down automatically during startup process.	LCD/LEDs and buzzer will be active for 3 seconds and then complete off.	The battery voltage is too low. (<1.91V/Cell)	1. Re-charge battery. 2. Replace battery.
No response after power on.	No indication.	1. The battery voltage is far too low. (<1.4V/Cell) 2. Battery polarity is connection reversed.	1. Check if batteries and the wires are connected properly. 2. Re-charge battery. 3. Replace battery.
Mains exist but the unit works in battery mode.	Input voltage is displayed as 0 on the LCD and green LED is flashing.	Input protector is tripped.	Check if AC breaker is tripped or AC wiring is connected right .
	Green LED is flashing.	Insufficient quality of AC power. (Shore or Generator)	1. Check if AC wires are too thin and/or too long. 2. Check generator (if applied) is working well or check if input voltage range setting is correct. (Appliance – Wide)
When the unit is turned on, internal relay is switched on and off repeatedly.	LCD display and LED are flashing.	Battery is disconnected.	Check if battery wires are connected right .
Buzzer beeps continuously and red LED is on.	Fault code 07	Overload error. The inverter is overload 110%and time is up.	Reduce the connected load by switching off some equipment.
	Fault code 05	Output short circuited.	Check if wiring is connected right and remove abnormal load.
	Fault code 02	Internal temperature of inverter component is over 90°C.	Check whether the air flow of the unit is blocked or whether the ambient temperature is too high.
	Fault code 03	Battery is over charged.	Return to repair center.
		The battery voltage is too high.	Check if spec and quantity of batteries meet requirements.
		AC input L/N wires are reversed	Check AC input.
	Fault code 01	Fan fault.	Replace the fan.
	Fault code 06/58	Output abnormal .(Inverter voltage below than 95Vac or is higher than 150Vac)	1. Reduce the connected load. 2. Return to repair center
	Fault code 08/09/53/57	Internal components failed.	Return to repair center
	Fault code 51	Over current or surge.	Reduce the connected load.
Fault code 52	Inverter bus voltage is too low or component temperature is to high.	Restart the unit, if the error happens again, please return to repair center.	
Fault code 55	Output voltage is unbalanced.		
Fault code 56	Battery is not connected right or fuse is burnt.	If the battery is connected well, please return to repair center.	

**Appendix: Approximate Back-up Time Table**

Model	Load (W)	Backup Time @ 24Vdc 100Ah (min)	Backup Time @ 24Vdc 200Ah (min)
2.5KW/ 3.0KW/ 3.5KW	300	449	1100
	600	222	525
	900	124	303
	1200	95	227
	1500	68	164
	1800	56	126
	2100	48	108
	2400	35	94
	2700	31	74
	3000	28	67
3200	25	58	
3500	22	50	
Model	Load (W)	Backup Time @ 48Vdc 100Ah (min)	Backup Time @ 48Vdc 200Ah (min)
5.5KW	500	613	1288
	1000	268	613
	1500	158	402
	2000	111	271
	2500	90	215
	3000	76	182
	3500	65	141
	4000	50	112
	4500	44	100
	5000	40	90

**Note:** Backup time depends on the quality of the battery, age of battery and type of battery. Specifications of batteries may vary depending on different manufacturers.

# Wi-Fi Kit

## Quick Installation Guideline



SmartESS(iOS)



SmartESS(Android)

## 2. Wireless Router Connection

### 2.1 Download APP and Wi-Fi connection

- ① Scan the QR Code from the cover of this guideline and download the APP.
- ② Select the same number of Wi-Fi Kit PN to connect on your phone WLAN. (Initial Password:12345678)

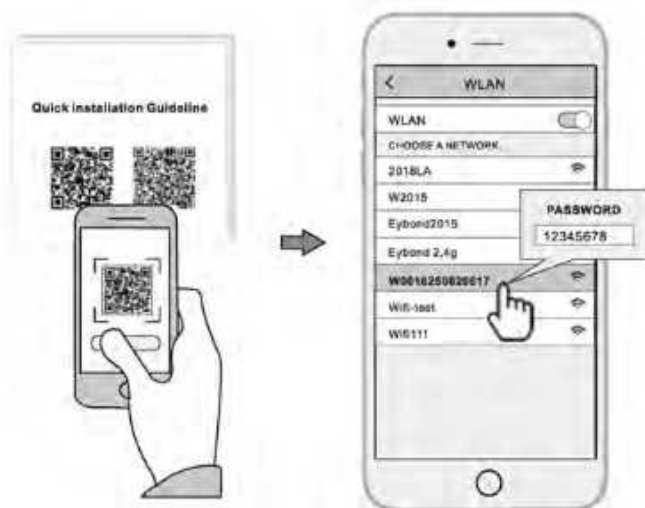

## 2.2 Wi-Fi Config

- ① Open the APP, Tap the **Wi-Fi Config** button to enter this page.
- ② Then tap the **Network Setting** button.

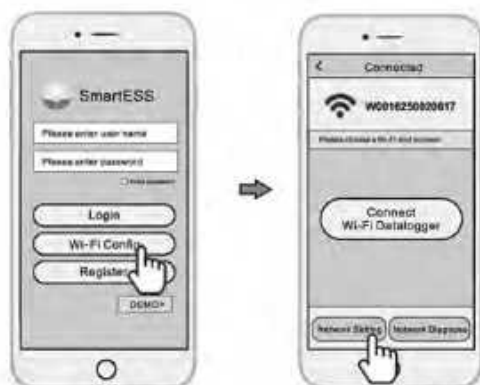

## 2.3 Network Setting

- ① According to the prompts, type in the information to finish the network setting.
- ② After the Wi-Fi Kit is restarted, reconnect the Wi-Fi which connected by step 2.1.

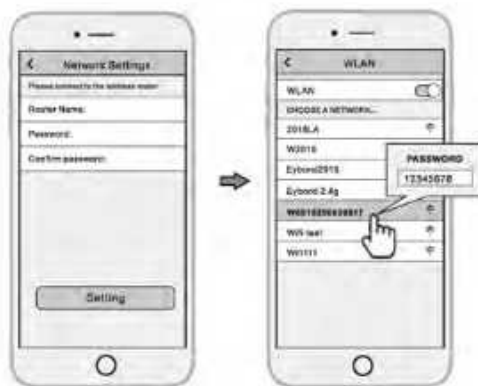

### 3. Create Account And Datalogger

#### 3.1 Create Account

- ① Open the APP, tap the **Register** button.
- ② According to the prompt information, complete creating an account.

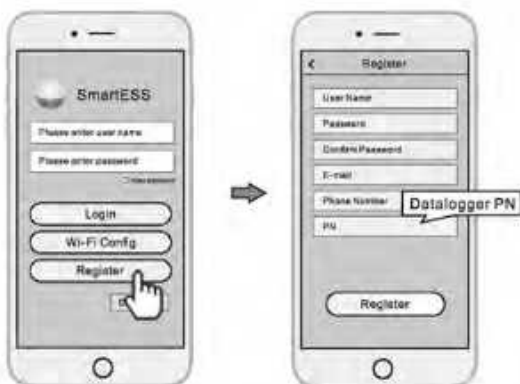

#### 3.2 Add Datalogger

- ① Login the account and click the list button on the bottom of the home page.
- ② Tap the "+" button on the top-right corner of the list page.
- ③ Scan the datalogger PN on the Wi-Fi Kit, or input it manually.
- ④ According to the prompts, type in the information to finish add datalogger.

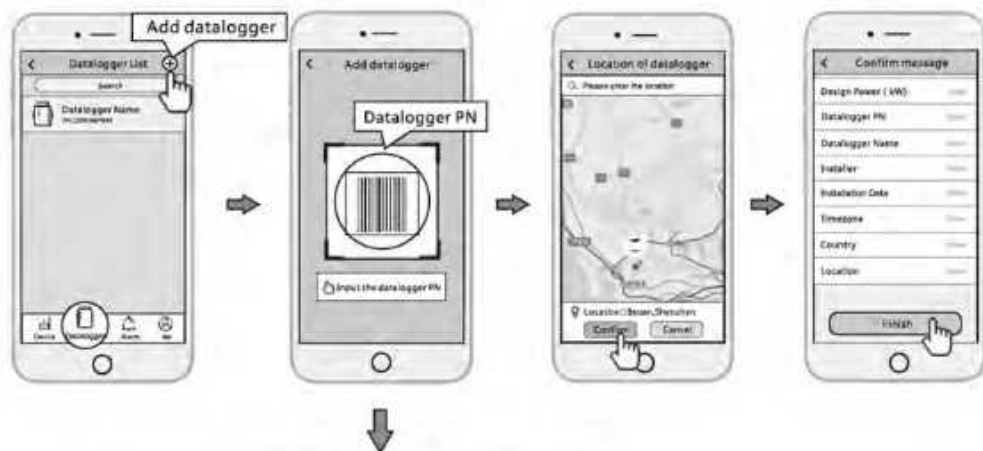

On the lower left of the chassis cover







# MEDALPOWER

Leave Power for Medal Power

[www.medal-power.com](http://www.medal-power.com)

