



MEDALPOWER

INVERTER

2KVA

Medal Power Inverter

MPI-2000VA#24VT



www.medal-power.com

TABLE OF CONTENT

1.	Important Safety Instructions.....	1
2.	Description.....	3
3.	Operation.....	6
4.	Installation.....	12
5.	Troubleshooting.....	19
6.	Technical Data.....	20
7.	Warranty scope	21

1. IMPORTANT SAFETY INSTRUCTIONS

SAFETY INSTRUCTIONS

1.1 General

Please familiarize yourself with the safety features and instructions by first reading the documentation supplied with this product before using the equipment. This product has been designed and tested in accordance with international standards. The equipment must be used exclusively for the purpose for which it was designed.



The product is used in conjunction with a permanent energy source (battery). Input and/or output terminals may still be dangerously energized, even when the equipment is switched off. Always switch off the AC supply and the battery before carrying out maintenance or servicing the product.

The product has no internal user-serviceable components. Do not remove the front plate or operate the product if any panels have been removed. Only Qualified personnel must undertake all servicing.

Never use the product in around where there is a risk of gas or dust explosions. (before using) Consult the battery manufacture's to confirm the products if can be used with the battery. Always comply with the battery manufacturer's safety instructions.

1.2 Installation

Read the installation instructions in the installation manual before installing the equipment.

This is a Safety Class I product (supplied with a protective grounding terminal). Uninterruptible protective grounding must be provided at the AC input and/or output terminals. Alternatively the grounding point

located externally on the product may be used. Whenever it is likely that the grounding protection has been damaged, the product must be turned off and secured against unintended operation.

Ensure that the DC and AC input cables are fused and fitted with circuit breakers. Never replace a safety component with a different type. Always consult the manual to determine the correct component.

Before applying power, ensure that the available power source matches the required specification of the product as described in the manual.

Ensure that the equipment is used under the correct ambient conditions. Never operate the product in a wet or dusty environment. Ensure there is adequate free space for ventilation around the product and check that the ventilation vents are not blocked.

Ensure that the required system voltage does not exceed the product's capacity.

1.3 Transport and Storage

Ensure that the mains power and battery leads have been disconnected before storing or transporting the product.

No liability can be accepted for any transport damage if the equipment is shipped in non-original packaging.

Store the product in a dry environment; the storage temperature must be between -20°C and 60°C.

Consult the battery manufacturer's manual in respect of transport, storage, charging, recharging and disposal of the battery.

2. DESCRIPTION

Fig. 1: rear plate

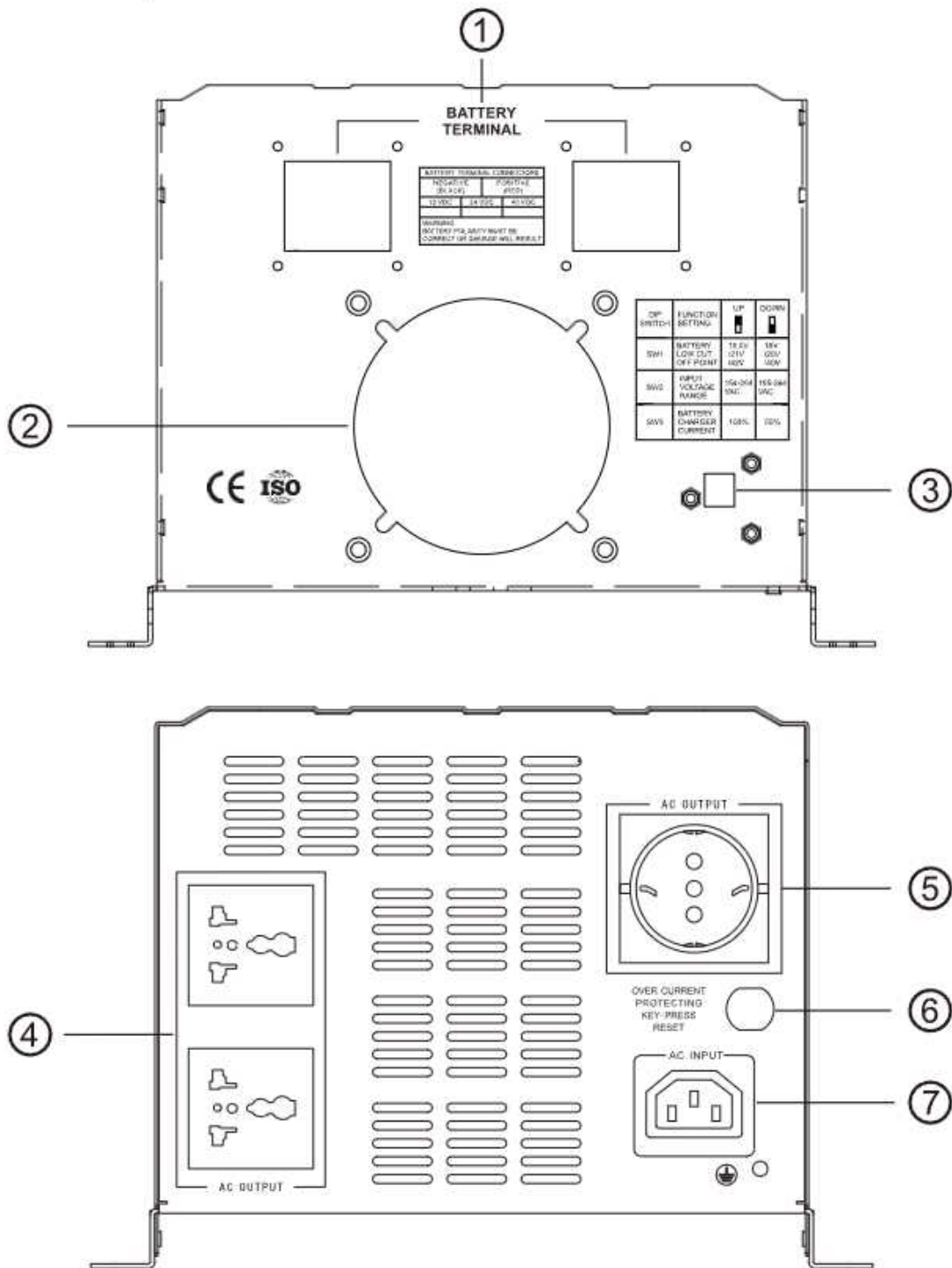

1...Battery terminal

2...Fan

3...Dip switches

4...Output seat

5...Output seat

6...Fuse(Recoverable over current protector)

7... Input seat

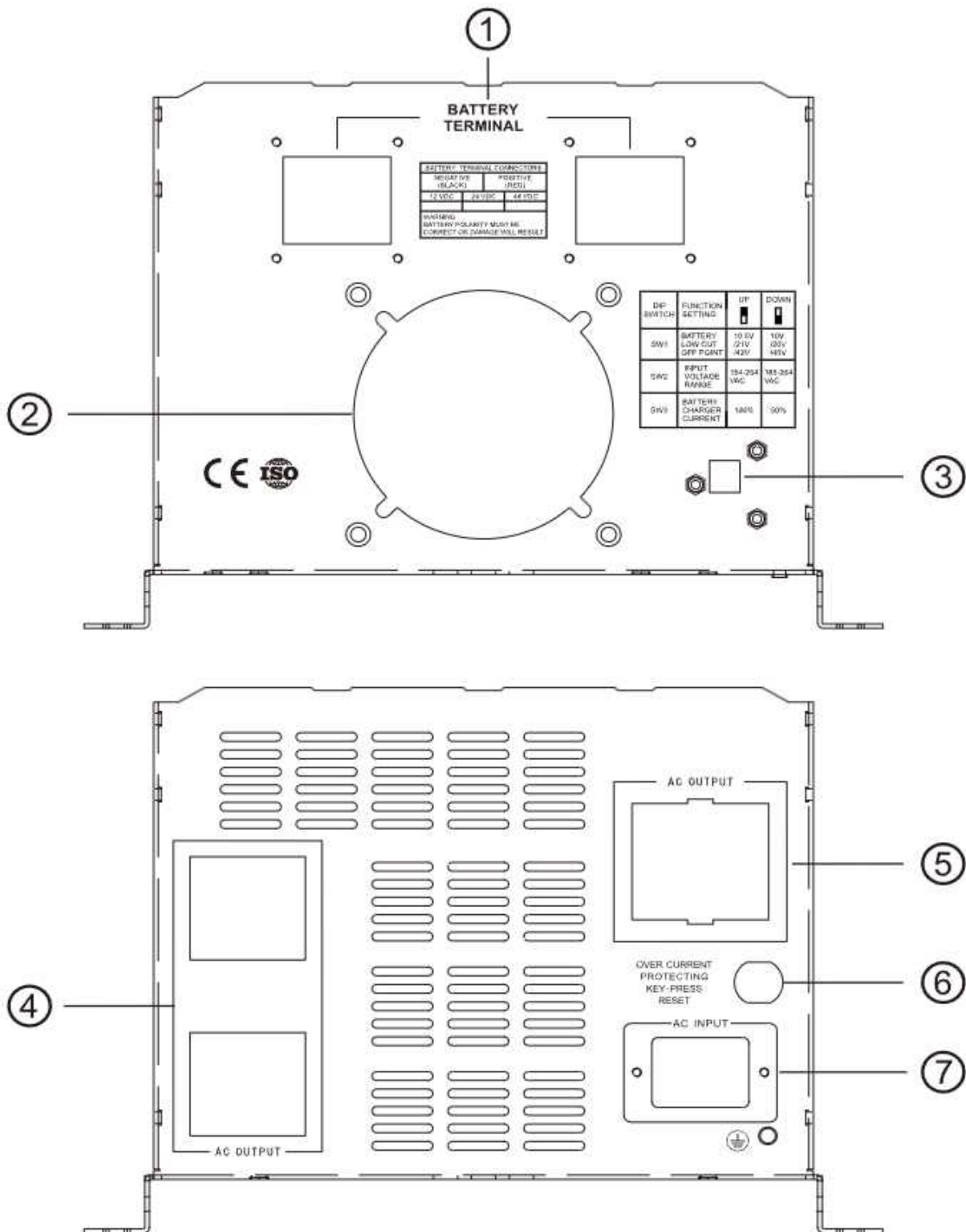

1...Battery terminal

2...Fan

3...Dip switches

4...Output seat

5...Output seat

6...Fuse(Recoverable over current protector)

7... Input seat

Fig 2: LCD Screen

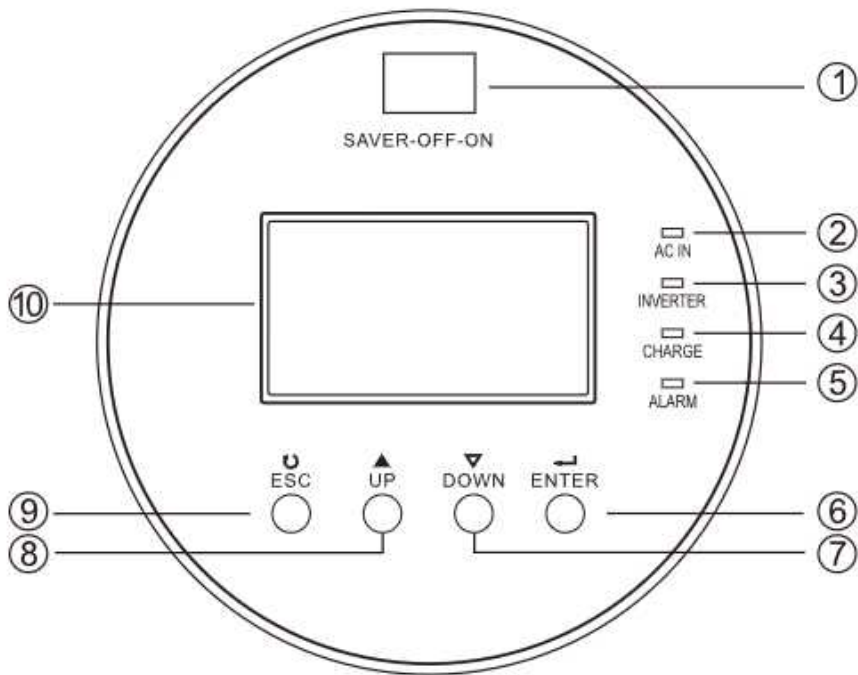

- | | |
|-----------------|----------------------|
| 1、 Power button | 6、 Confirm Key |
| 2、 AC In LED | 7、 Page Down Key |
| 3、 Inverter LED | 8、 Page UP Key |
| 4、 Charge LED | 9、 Escape Key |
| 5、 Alarm LED | 10、 Indicator Screen |

Fig 3: Power Button

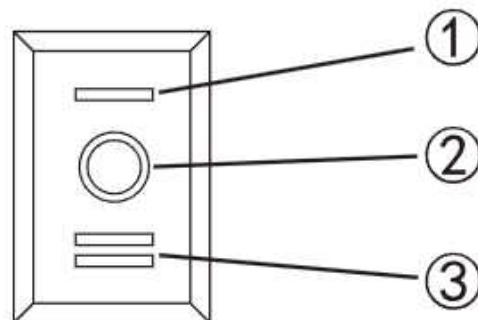

- | | |
|--------|------------|
| 1..... | Saver Mode |
| 2..... | Off Mode |
| 3..... | On Mode |

3. OPERATION

3.1 AC In

When power button is switched to “on”, the product is fully functional. The inverter will come into operation and the green LED “AC In” will light up.

3.2 Inverter Mode

In the event of a grid failure, or generator power being disconnected, the unit switches to inverter mode and takes over supply to the connected loads. This happens so fast (less than 10 milliseconds) that computers and other electronic equipment will continue to operate without disruption. The green LED light of “Inverter” indicates on the LCD panel

3.3 Charging Mode

In the event of restoration of grid, or generator power, the Inverter commences charging. The “AC In” green LED light comes up, and the orange “Charge” light starts blinking. When the batteries are fully charged, the blinking orange light changes to Solid Orange.

3.4 Alarm Mode

In the event of high battery discharge, and it gets close to the battery cutoff level, the red “Alarm” light starts showing, and it is accompanied with a beeping sound, this continues until the units gets to the battery voltage cutoff level and it powers down automatically, except there is a restoration of grid supply in which case it changes back to charging mode.

3.5 Bypass Functionality:

When the power control button is switched to “**OFF**”, and there is a grid or generator supply, the inverter supplies output to the load and also charges.

When the power control button is switched to “**OFF**”, and there is no grid or generator supply, the inverter supplies does not supply output to the load.

3.6 Saver Mode

When the power control button is switched to “**SAVER**”, and there is no supply of grid, the inverter's AC output will not be supplied until a load greater than 15 watts is connected to the inverter. It automatically detects the connected load every 15 seconds.

Tab.I

MODE	BUTTON	NO AC SUPPLY	AC SUPPLY
SAVER	I	≤15W LOAD,NO O/P	CHARGING,O/P
		≥15W LOAD,O/P	
ON	II	INVERTER	CHARGING,O/P
OFF	O	NO O/P	CHARGING,O/P

Tab.II

DIP SWITCH	FUNCTION	UP	DOWN
SW 1	BATTERY LOW CUT OFF POINT	10.5V/21V/42V	10V/20V/40V
SW 2	INPUT VOLTAGE RANGE	154-265/83-132 VAC	185-265/96-132 VAC
SW 3	BATTERY CHARGER CURRENT	100%	50%

3.7 Setting Mode

Quick setting mode

Long press the "ENTER" button for 5S , and then release the button. The display automatically enters the setting interface "Quick Setting", select the parameters through the "UP" and "DOWN" buttons, and then press the "ENTER" button to lock the parameters in the setting item interface that needs to be changed, and then press the "UP" and "DOWN" buttons is used for setting. After the setting is completed, press the "ENTER" button again, the screen will prompt whether the setting is successful.

Settable items	Parameters	Descriptions
Beep Status Buzzer mode	ENABLE	Allows beeping in fault state
	DISABLE	No beeping in any state
Backlight Type Backlight mode	ON	The display backlight is always on
	OFF	The display backlight is always off
	DELAY	Display backlight smart switch

Advanced setting mode

Press the button "ESC" and "ENTER" together and then release them. It will be in setup mode when the screen shows "Password:00000". The password is 12345, press the button "UP" or "DOWN" to enter the password. After password entering, choose the option "Yes" and press the button "ENTER" so as to confirm the password .

After confirming the password, enter the setting interface "Advanced Setting", use the "UP" and "DOWN" buttons to select parameters, and then press the "ENTER" button to lock the parameters in the setting item interface that needs to be changed, and then press "UP" and the "DOWN" buttons to set. After the setting is completed, press the "ENTER" button again , the screen will prompt whether the setting is successful.

Settable Items	Parameters	Descriptions
AcV Range Type Input range	NARROW	Mains input range is 180~265V
	WIDE	Mains input range is 155~265V
AcF Range Type Input frequency range	NARROW	Mains input frequency range is 45~65HZ
	WIDE	Mains input frequency range is 40~70HZ
Work Mode Type Charging priority	Utility First	The utility power will provide power to the load first. Only when the utility power is not enough to supply the load, the solar energy And the battery will provide power to the load.
	Solar First	When solar energy is sufficient, solar energy will be preferentially provided to the load. When there is solar energy but not enough, the solar energy and battery power will provide power to the load at the same time. When there is no solar power, the utility will provide power to the load. At the same time, If the battery voltage drops to the low-battery warning voltage point or the set DC-to-AC voltage point, the mains will also provide power to the load.
	Dc First	When solar energy is sufficient, solar energy will be preferentially provided to the load. When there is solar energy but not enough, the solar energy and battery power will provide power to the load at the same time. If the battery voltage drops to the low battery warning voltage point or the set DC to AC voltage point, the mains will provide power to the load.
Charge Mode Type	Utility First	The energy of the mains and the solar energy charge the battery at the same time.
	Solar First	In the solar priority mode, when the PV meets the requirements, the battery is charged with solar energy preferentially, and when the battery voltage is too low, the mains charge will be started.
	Solar Only	The machine simply uses the energy of solar energy to charge the battery.
AcCha Percent Mains charging curren	0~100%	Adjustable charging current ratio of mains
SolCha Percen Solar charging	0~100%	You can adjust the charging current proportional solar
Bulk Cha Vol Bulk charging voltage setting	13.5~15V	Bulk charging voltage setting, according to different types of batteries
	27~30V	
	54~60V	
Float Cha Vol Float voltage setting	12.5~14V	Float voltage setting, according to different types of batteries
	25~28V	
	50~56V	

BatLowLock Vol Shutdown voltage	9.5~11.5V	Set the shutdown voltage point of battery protection voltage
	19~23V	
	38~46V	
SolarToAc Vol Return to the mains charging voltage point	11.5~12.5V	Set the battery voltage point when the mains power is involved in the solar energy priority charging mode
	23~25V	
	46~50V	
Ac To Dc Voltage	13~14V	Select the voltage point of converting from mains to solar power in solar priority mode
	27~28V	
	54~56V	
Inv Output Vol Output voltage	200~240V	Set the inverter output voltage
AcC Speed Type Mains sensitivity	HIGH	Mains sensitivity settings: high medium low
	MID	
	LOW	
Inv Fre Type Output frequency	50/60HZ	Set inverter output frequency
Restart Allow Restart	ALLOW	Restart 3 times after short circuit or overload
	NOTALLOW	No restart after short circuit or overload
Backlight Type Backlight mode	ON	The display backlight is always on
	OFF	The display backlight is always off
	DELAY	Display backlight smart switch
Beep Status Buzzer mode	ENABLE	Allows beeping in fault state
	DISABLE	No beeping in any state
Bat Cap Limit	ON	Intelligent battery protection function, it is not recommended to change
	OFF	
Load Limit	ON	Intelligent transformer temperature protection function, it is not recommended to change
	OFF	
Load Offline Warn	ON	This setting does not adapt to this inverter. Setting not available.
	OFF	
Outside Uart Baud	2400	Set the communication baud rate
	4800	
	9600	
Output Mode	220	Set display output voltage
	110	
Swon Bat Voltage	10.5~12.2V	After the machine is shut down abnormally, the battery voltage must be higher than the set value before it can be turned on normally
	21~24.4V	
	42~48.8V	
Low Off Restart Vol	12~14V	After the machine is powered off at low power, the battery voltage is higher than the set value and it can be automatically turned on
	24~28V	
	48~56V	

Battery Type	SEL	Sealed Lead Acid Battery
	GEL	Gel Battery
	FLD	Inter Cell
	USER	Customer Customization
	LiCoMnNi02	Ternary Lithium Battery
	BAT-LiFePO4	Lithium Iron Phosphate Battery
Factory Reset	YES	All settings are restored to factory settings
	NO	No recovery process, keep existing settings
BMS Function Switch	On	Whether to enable the BMS communication function
	Off	
Bat Soc Under Lock	5~50%	BMS low voltage SOC value, if the BMS SOC value is lower than the set value, the inverter will shut down to protect the battery
Bat Soc Turn To Ac	5~50%	When the working mode of the inverter is set to the battery priority mode, the inverter will be forced to enter the mains charging when the SOC of the BMS is lower than the set value.
Bat Soc Turn To Dc	50~100%	When the working mode of the inverter is set to the battery priority mode, the inverter resumes the DC working mode when the SOC of the BMS is higher than the set value.
Bat Restart Soc	30~100%	When the inverter is turned on, the SOC must be higher than the set value to work normally.
Factory Reset	On	All settings are restored to factory settings
	Off	No recovery process, keep existing settings
ECO Mode	On	ECO mode switching
	Off	

4. INSTALLATION

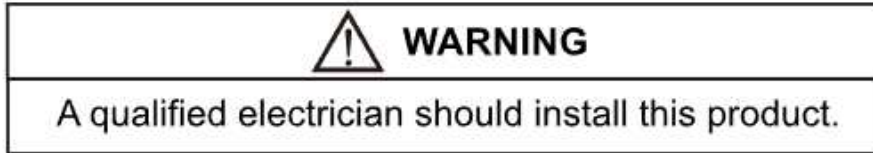

4.1 Locating and Mounting the Inverter

The product must be installed in a dry and well-ventilated area, as close as possible to the batteries. There should be a clear space of at least 10cm around the appliance for cooling.

Excessively high ambient temperature will result in the following:

- Reduced service life.
- Reduced charging current.
- Reduced peak capacity, or shutdown of the inverter.

Never mount the appliance directly above the batteries.

The product is suitable for wall mounting. For mounting see Fig. 1.

The appliance can be mounted horizontally as well as vertically; vertical mounting is preferable. The vertical position offers optimum cooling.

The interior of the product must remain accessible after installation.

Try and keep the distance between the product and the battery to a minimum in order to minimize cable voltage losses.

For safety purposes, this product should be installed in a heat-resistant environment if it is used with equipment where a substantial amount of power is to be converted. You should prevent the presence of e.g. chemicals, synthetic components, curtains or other textiles, etc., in the immediate vicinity.

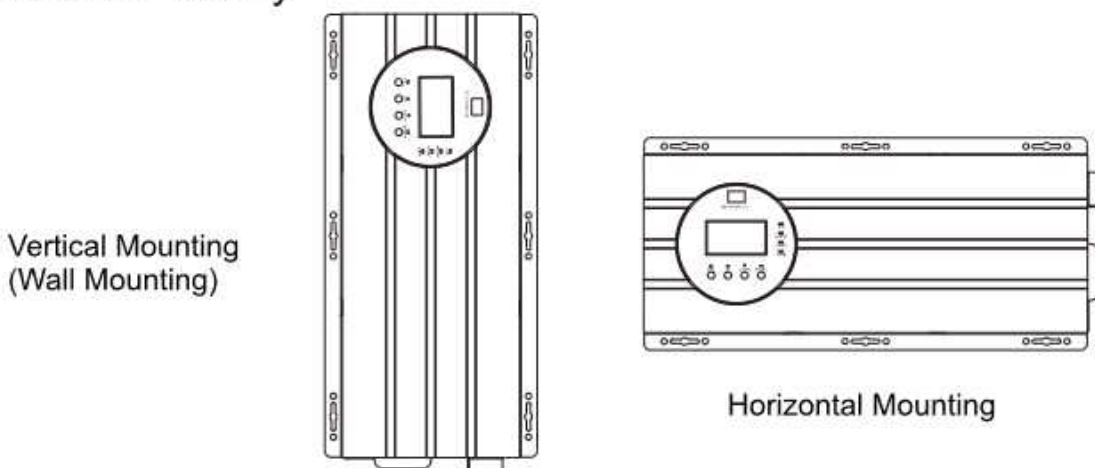

Approved orientations for inverter mounting.

4.2 AC Wiring

This is a Safety Class I product (supplied with a protective grounding terminal). **Uninterruptible protective grounding must be provided at the AC input and/or output terminals and/or chassis grounding point located externally on the product.**

AC Wiring should be connected in the following order:

- **AC INPUT (Source)**
- **AC OUTPUT (Load)**



Fig 4:AC input/Output Connections

AC Input: The inverter comes installed with Input protection circuit breaker. This should be switched off before the cable is installed.

Remove the AC wiring compartment cover to gain access to the AC terminal strip inside.

Run the three conductors AC INPUT (source) wiring into the wiring compartment. Connect the AC INPUT ground wire first to the ground terminal (ground symbol with circle around it), and then connect the AC INPUT line (L) and neutral wire (N) to the corresponding AC input terminals.

AC Output: The inverter comes installed with Input protection circuit breaker. This should be switched off before the cable is installed. In a similar manner, connect the AC OUTPUT (load) wiring to the Inverter AC output terminal as was done on the AC Input

After wiring, double check and review all connections to make sure the wires are in the correct terminals and the terminals are tight

To ensure the best performance from your inverter system,do not use old or untested batteries.Batteries should be of the same size,type, rating,and age.

AC Safety Grounding: During the AC wiring installation,AC input and output ground wires are connected to the inverter.The AC input ground wire must connect to the incoming ground from your AC utility source. The AC output ground wire should go to the grounding point for your loads (e.g.a distribution panel ground bus).

4.3 DC Wiring:

 WARNING
<p>DO NOT connect the DC wires from the battery bank to the inverter until:</p> <ul style="list-style-type: none">● All AC wiring is complete,● The correct DC and AC protection switches are OFF● The correct DC voltage and polarity have been verified

Depending upon the type of batteries you use in the installation (6 or 12 VDC),the batteries must be wired in series,parallel,or series-parallel. The interconnecting DC wires must be sized and rated exactly the same as those that are used between the battery bank and the inverter.

To ensure the best performance from your inverter system,do not use old or untested batteries.Batteries should be of the same size,type, rating,and age.

4.3.1 procedure

In order to fully utilize the full capacity of the product,batteries with sufficient capacity and battery cables with sufficient cross section should be used.

Proceed as follows to connect the battery cables:

 WARNING
<ul style="list-style-type: none">• Use an insulated box spanner in order to avoid shorting the battery.• Avoid shorting the battery cables.

Connect the battery cables: the + (red) on the left and the -(black) on the right, to the battery. Reverse polarity connection (+ to - and - to +) will cause damage to the product. (Safety fuse inside the Inverter unit can be damaged)

The DC overcurrent device (i.e., fuse or circuit breaker) must be placed in the positive (RED) DC cable line between the inverter's positive DC terminal and the battery's positive terminal (RED); as close to the battery as possible.

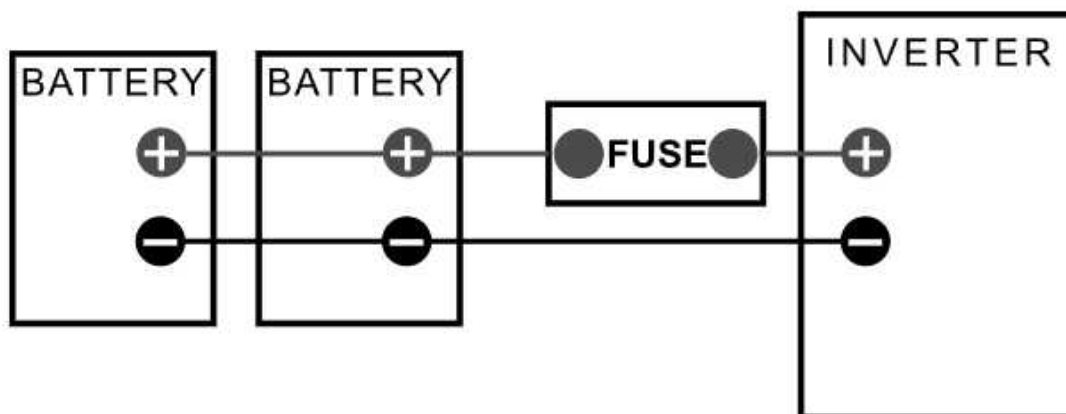

Fig 5: Inline fuse

A brief spark or arc may occur when connecting the battery cables to the inverter DC terminals; this is normal and due to the inverter's internal capacitors being charged.

All wiring to the battery terminals should be checked periodically (once a month) for proper tightening

Secure the nuts tightly in order to reduce the contact resistance as much as possible.

Be aware that over-tightening or misthreading the nuts on the DC terminals can cause the bolts to strip and snap/break off.

4.3.2 DC Wiring Size

It is important to use the correct sized DC wire to achieve maximum efficiency from the system and to reduce fire hazards associated with overheating. Always keep your wire runs as short as practical to prevent low voltage shutdowns and to keep the DC breaker from nuisance tripping (or open fuses) because of increased current draw.

The correct minimum DC wiresize (and corresponding overcurrent device) is required in order to reduce stress on the inverter, minimize voltage drops, increase system efficiency and ensure the inverter's ability to surge heavy loads.

If the distance from the inverter to the battery bank is ≤ 5 feet, use a minimum DC wire size of #2 AWG (33.6 mm²). If the distance between the inverter and the battery is > 5 feet, the DC wire will need to be increased. Longer distances cause an increase in resistance, which affects the performance of the inverter.

Tab.III

Models	Minimum DC Wire Size(rating)	Maximum DC Fuse size	DC Grounding wire size
1512/24/48	25/16/8mm ²	160/80/50A	2.5mm ²
2012/24/48	32/16/8mm ²	200/100/50A	2.5mm ²
3012/24/48	50/25/16mm ²	250/150/80A	2.5mm ²

4.3.3 Parallel and Series Connection

12 Volts Battery In Parallel

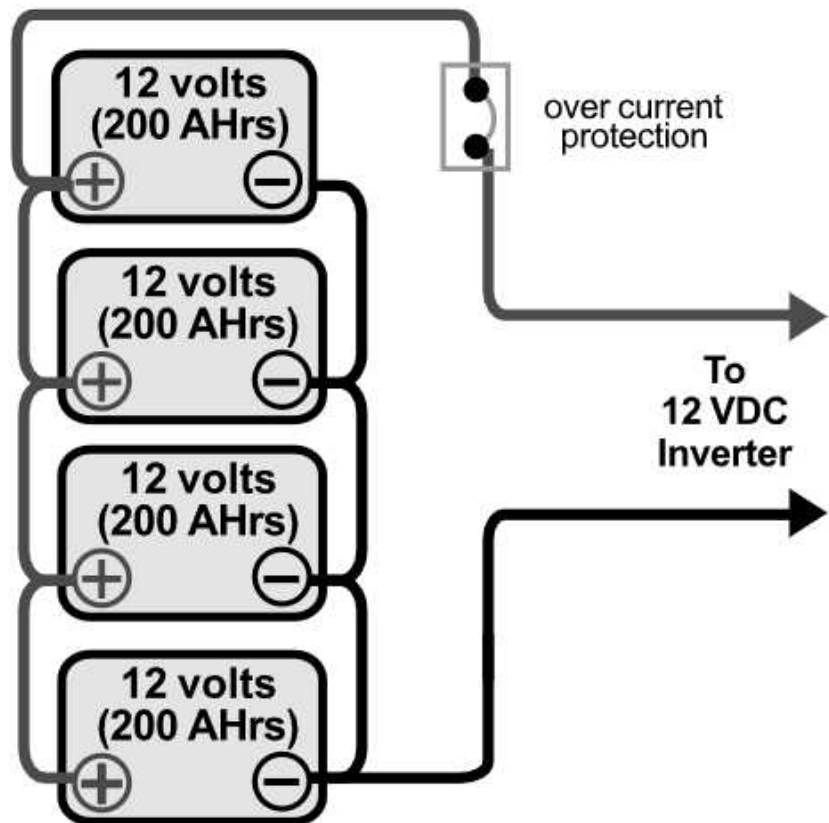

12 volt battery (total capacity=800 Ah)

Fig 6. Parallel Battery Wiring

12 volts Battery in Series

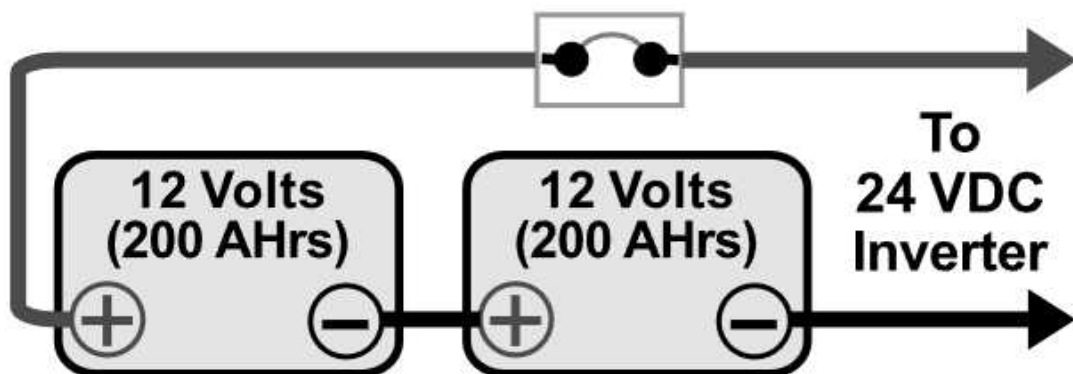

24 Volts battery (total capacity=200 Ah)

Fig 7. Parallel Battery Wiring

Difference between Series and Parallel connection

Batteries in Parallel

Voltage remain the same
Ah capacity doubles

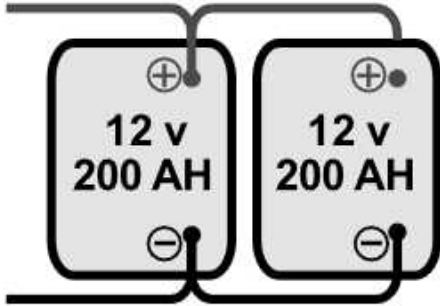

System Voltage = 12Volts
Ah Capacity = 400AH

Batteries in Series

Voltage doubles
Ah capacity stays the same

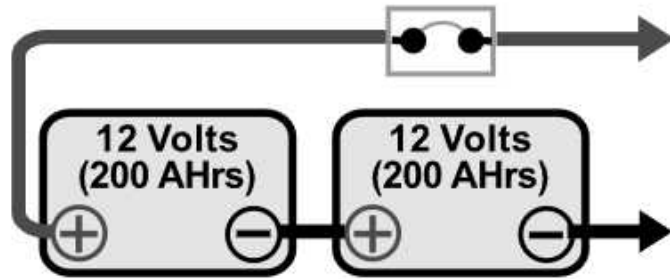

System Voltage=24V
Ah Capacity=200AH

Tab.IV

Models	DC Rating (Volts)	Minimum Batteries	Maximum Batteries
1512/24/48	12/24/48V	1/2/4	3/6/8
2012/24/48	12/24/48V	1/2/4	3/6/8
3012/24/48	12/24/48V	1/2/4	3/6/8

5. TROUBLESHOOTING

Proceed as follows for quick detection of common faults. DC loads must be disconnected from the batteries and the AC loads must be disconnected from the inverter before the inverter and/or battery charger is tested.

Consult your local dealer/repair center if the fault cannot be resolved.

Tab.V

Problem	Cause	Solution
The inverter fails to operate when switched on	Battery terminal not firm	Tighten the battery terminals.
Continuous spark from the inverter terminal	Battery terminal reversal	Check and connect the cable to the right terminal lead.
No output from inverter	Output cable terminals loosed	Open the casing and connect the output cable terminals firm to the appropriate lead.
Inverter not charging battery	input power less than(<) 150/83~96VAC	A step-up stabilizer of rating higher than the inverter should be installed.
Continuous alarm when the inverter is loaded	Overloading condition	Check the loads and disconnect heavier loads.

6. TECHNICAL DATASHEET

MODEL	1512/24/48	2012/24/48	3012/24/48
Input			
Capacity (VA)	1500VA	2000VA	3000VA
Voltage (DC)	12/24/48V	12/24/48V	12/24/48V
Nominal Voltage	220VAC/110VAC		
Voltage Range	154-265VAC/77-135VAC		
Frequency	50-60Hz Auto sensing		
Output			
Voltage	220VAC/110VAC		
Frequency	50/60Hz		
Waveform	Pure sinewave		
Transfer time(AC to DC)	<8ms		
Transfer time(DC to AC)	<8ms		
Output voltage regulation	10%rms		
Bypass Mode	Yes		
Saver Mode	Yes		
Efficiency	>98%		
Protection			
Input Protection	Circuit Breaker		
Output Protection	Circuit Breaker		
Battery			
Battery Type	AGM-Deep Cycle,GEL		
	Up to 500Ah		
Charging current	30/15/7A	35/18/9A	58/29/15A
Low Level disconnect(Selectable)	12V:(10V or 10.5V) 24V:(20V or 21V) 48V:(40V or 42V)		
LCD Indicator status	Input AC,Output AC Battery DC,Output Load Alarm,Fault Battery Charge Level Output Frequency		
LED Indicator status	AC Line In:Green Inverter:Green Charging:Yellow Alarm:Red		
Battery low alarm	12V:battery light discharge 11.5V; battery load discharge 11.5V@load<20% ; 11V@load>50%/10.5V@load>50% ; 24V:battery light discharge 23V; battery load discharge 23V@load<20% ; 22V@load>50%/21V@load>50% ; 48V:battery light discharge 46V; battery load discharge 46V@load<20% ; 44V@load>50%/42V@load>50% ;		
Battery low recovery	12V:battery light discharge 12V ; battery load discharge 12V@load<20% ; 11.5V@load>50%/11V@load>50% ; 24V:battery light discharge 24V ; battery load discharge 24V@load<20% ; 23V@load>50%/22V@load>50% ; 48V:battery light discharge 48V ; battery load discharge 48V@load<20% ; 46V@load>50%/44V@load>50% ;		
DC low voltage shutdown	12V:battery light discharge 11V ; battery load discharge 11V@load<20% ; 10.5V@load>50%/10V@load>50% ; 24V:battery light discharge 22V ; battery load discharge 22V@load<20% ; 21V@load>50%/20V@load>50% ; 48V:battery light discharge 44V ; battery load discharge 44V@load<20% ; 42V@load>50%/40V@load>50% ;		
DC high voltage alarm and fault	16V/32V/64V		
DC high voltage recovery	15V/30V/60V		

Alarm	
Low battery alarm	Audible alarm-1 beeping per second
Overload alarm	Audible alarm-continuous beeping
Fault	Audible alarm-continuous beeping
Environment	
Temperature	-10~50°C
Humidity	C0-95 %, Non condensing
Accoustic Noise(db)	<45dB

7. Warranty scope:

The following is not within the scope of warranty:

- (a) Battery configured by user.
- (b) Do not operate according to the user's manual, resulting in damage to the machine.
- (c) Mechanical damage due to natural disasters such as fire, flood, etc.
- (d) Products beyond the warranty period, the implementation of paid maintenance services



MEDALPOWER

Leave Power for Medal Power

www.medal-power.com

