



MVD

www.mvd.com.tr

SERVO

Press Brakes

High
Productivity

Less Energy
Consumption

Quick Return
on Investment

Hydraulic Hybrid
Servo Press Brake

Screw Driven
Servo Press Brake

Belt Driven
Servo Press Brake

iBend The iBend logo icon, a green leaf with a white lightning bolt inside.



ABOUT US

MVD started machine production in 1950 and dedicated itself to develop industry with its superior quality and aftersales support mentality.

It has been a significant brand in sheet metal working machinery sector with its exports to 5 continents.

MVD has an active role in presenting and supporting its machines in more than 100 countries together with distributors and work partners. It is one of Turkey's top 5 exporters of its sector and a leading company for customer satisfaction and long term relations.

**50
YEARS**

1st Press Brake and
still working



50+

Branches and representative
offices all around the world



100+

Countries using
MVD machines



CONTENT

Hydraulic Hybrid Servo Press Brake

The pinnacle of efficiency, precision and power in metal bending technology. Combining hydraulic power with exacting servo motor precision, saving energy while increasing productivity, our hybrid press brakes deliver unmatched performance and efficiency.

Experience faster production, precise bends, and reduced energy consumption, all tailored with many options to meet the demands of modern manufacturing. Elevate your capabilities to set new standards in quality and sustainability.

04-13

Screw Driven Servo Press Brake

The screw driven servo press brake is another pinnacle of precision and efficiency. Ideal for industrial production, this advanced press brake excels in shaping metal sheets with speed, accuracy and reliability. This concept combines precision-engineered ball screw with servo motor drive. This synergy enables seamless, repeatable movements that not only increase production speed but also ensures consistent quality on every job.

MVD screw driven servo press minimizes setup times, optimizes workflow efficiency and precise movements makes it indispensable for achieving complex geometries and tight tolerances demanded by today's manufacturing standards. Discover how our screw driven servo press can elevate your production capabilities, setting new benchmarks in performance and reliability. Perfect for industries requiring uncompromising precision, energy efficiency and fast production.

14-21

Belt Driven Servo Press Brake

Top beam movement with belt and pulley system is powered by dual synchronous servo motors. This setup ensures high precision and efficiency during bending operations, and maintains work comfort by preventing noise and oil pollution. It has an innovative design incorporating springs to support the top beam, which effectively utilize stored energy for return movement and reduce electrical consumption.

The O-type housing design, unlike the traditional C-type housing, improves structural integrity and performance eliminating the effect of deflection on side frames, provides superior stability and reliability. With these advanced features, the belt driven servo press brakes set a new standard for productivity and quality in bending operations. They are engineered to meet the demanding requirements of modern manufacturing, ensuring each bend is at low cost and at premium quality.

22-29



iBend

Experience high efficiency and power with our iBend Hybrid Servo Press Brake. The Hybrid Servo Press Brake combines innovation with customer-oriented solutions to increase productivity and reduce electrical consumption at medium to high pressing capacities. Dual synchronous servo motors ensure precise ram control with less energy and less oil usage. This compact, all-in-one system offers higher working speeds and maintains the same stroke and bending force as hydraulic press brakes, providing superior efficiency and performance.



 MVD LinkedIn

**Synergy of servo precision
& hydraulic power**

www.mvd.com.tr

HYDRAULIC HYBRID

Servo Press Brake



High Power

High Productivity

Less Energy

Less Noise

Less Oil



iBend

Hydraulic Hybrid Servo Press Brake

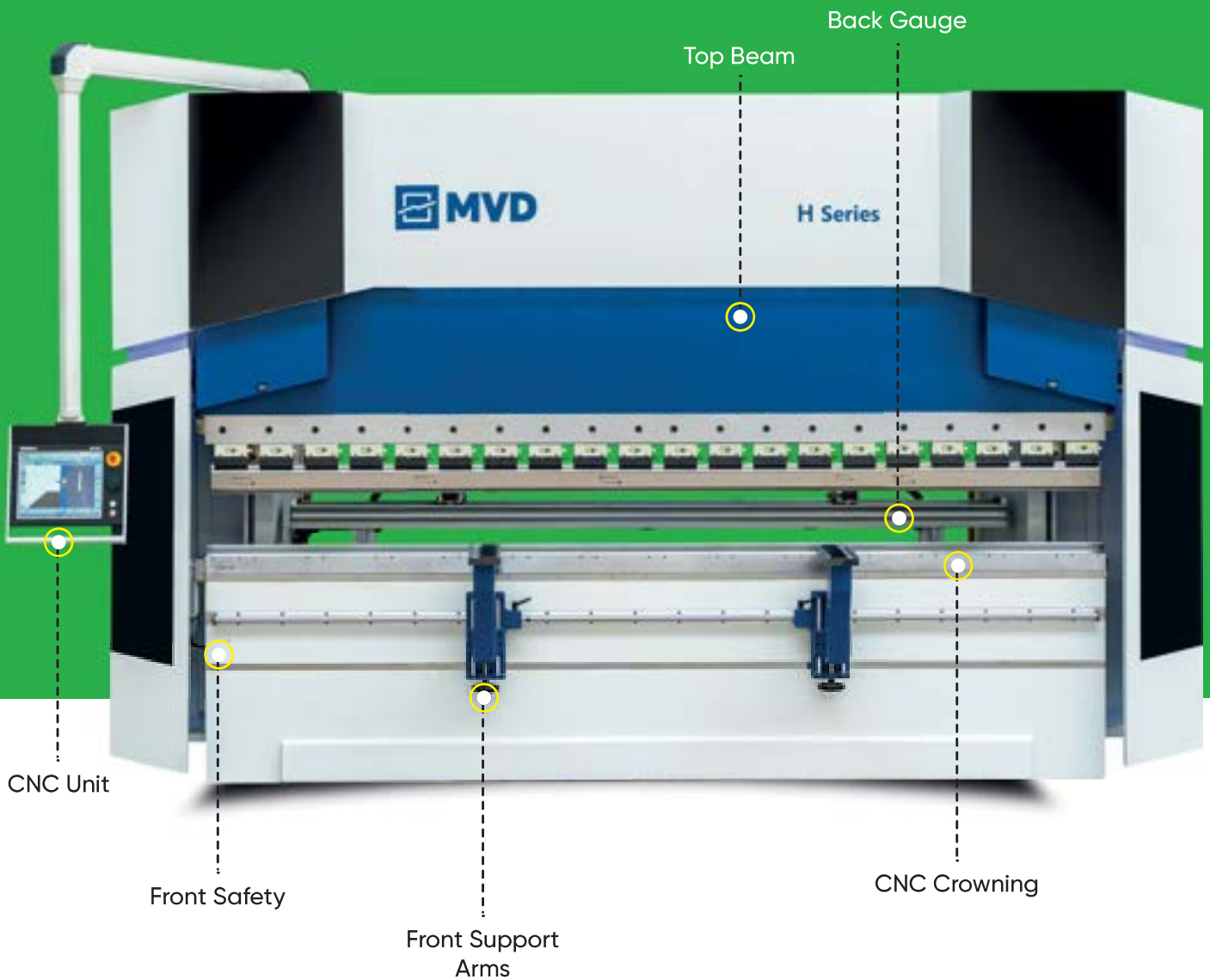

iBend / Hydraulic Hybrid Servo Press Brake



Standart Features

- Y1, Y2, X, R - 4 Axis CNC
- **Control Unit:** ESA S830
- **Stroke:** 260 mm HB Series; 310 mm HC Series
- **Throat Depth:** 410 mm
- **Back gauge:** Servo motorised X+R : Accuracy ± 0.03 mm | X: 750 mm | R: 250 mm
- **Back gauge finger:** 2x pcs, 3x stages
- **Top tool holder:** Promecam type quick clamping
- **Bottom tool holder:** Narrow specific MVD (European type)
- **Top tool:** Standard (H: 67 mm, 85°, R: 0.8 mm)
- **Bottom tool:** Standard (60x60 mm, 4 V die (16/22/35/50 in mm), 85°, H: 60 mm)
- **Linear scale:** GVI optic linear scale (0.005 mm resolution)
- Led lighting
- Sliding front support system
- Double foot pedal

Optional Features

- **Recommended control units:** Delem, ESA, Cybelec or Step
- **Crowning system:** Original WILA or MVD wedge
- **Front safety system:** AKAS II, AKAS LC5M or DSP
- **Backgauge:** MVD or UNIMEC (Gauge options Z1, Z2, X5, ATFL)
- **Bending follower arm:** MVD or UNIMEC
- **Hydraulic top and bottom die clamping:** WILA or Rolleri
- Bending laser line
- Laser angle measurement system
- Additional back gauge fingers

Advantages



Bending processes:
35 % Shorter



More excellent
bend results



Lower maintenance and
production costs



Less
Noise



Less
Oil



Less energy
consumption up to 60 %

iBend

Hydraulic Hybrid Servo Press Brake

Recommended Control Units

esa



S840, S840W, S860W, S875W

Delem



DA58Tx, DA66S, DA69S

CYBELEC



VisiTouch Pac, CybTouch 15

**STEP
AUTOMATION**



Rock 22+, Rock 17+, Rock 15+



*Screens are representational and may differ from what is shown visually.

iBend / Hydraulic Hybrid Servo Press Brake



SYNERGY OF SERVO PRECISION & HYDRAULIC POWER



Standard
X + R Axis Back Gauge



Standard
Quick Clamping



Standard
GVI Optic Linear Scales

Technical Specifications

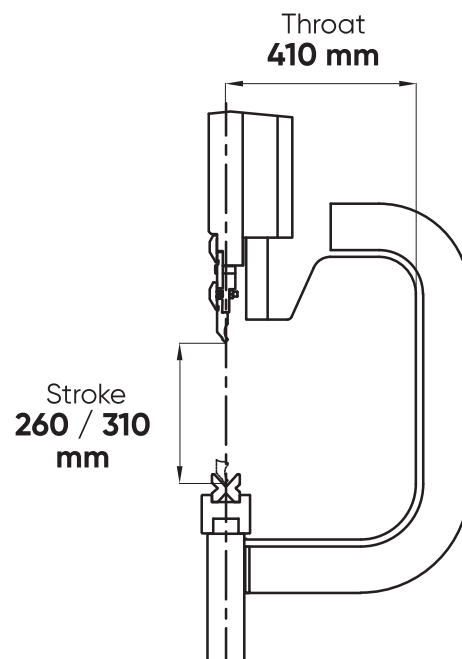
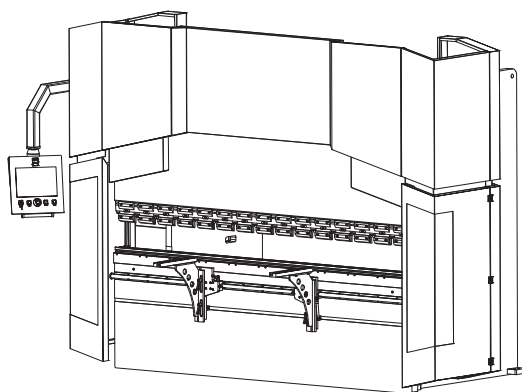
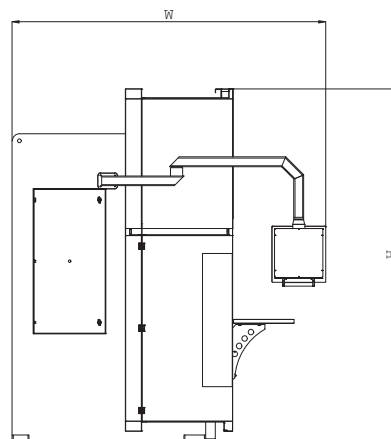
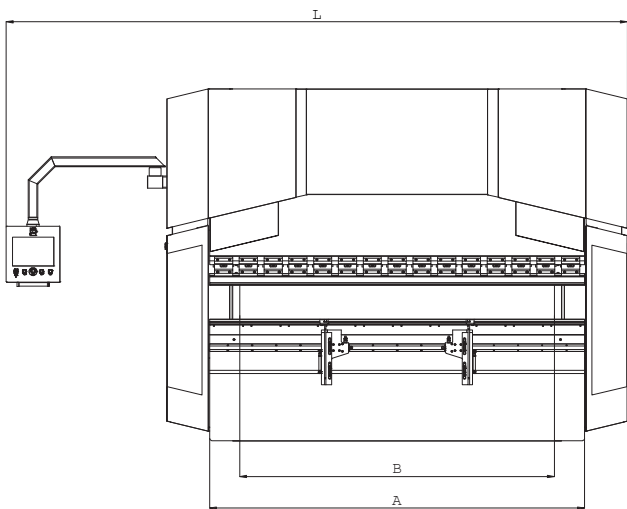

Servo Hybrid Press Brake		B-SERIES BASE (Stroke: 260 mm)			C-SERIES BASE (Stroke: 310 mm)				
General Features	Unit	HB135	HB175	HB220	HC100	HC135	HC175	HC220	HC270
Bending Force	Ton	135	175	220	100	135	175	220	270
Bending Length	mm	3100	3100	3100	3100	3100	3100	3100	3100
Distance between columns	mm	2600	2600	2600	2600	2600	2600	2600	2600
Stroke	mm	260	260	260	310	310	310	310	310
Throat	mm	410	410	410	410	410	410	410	410
Daylight	mm	465	465	465	515	515	515	515	535
Speed									
Ram closing speed	mm/s	250	250	250	250	250	250	250	250
Bending Speed	mm/s CE Norm	10	10	10	10	10	10	10	10
Return Speed	mm/s	250	250	250	250	250	250	250	250
Dimensions									
Length	mm	4690	4700	4720	4670	5150	5150	5180	5200
Width	mm	2340	2430	2430	2230	2650	2650	2650	2650
Height	mm	2980	2990	3000	3000	3000	3150	3150	3150
Table Height	mm	940	955	955	905	935	935	940	950
Backgauge									
Backgauge stroke of the X-Axis	mm	750	750	750	750	750	750	750	750
Backgaugefinger	pcs.	2	2	2	2	2	2	2	2
X Axis (Speed)	mm/s	400	400	400	400	400	400	400	400
R Axis (Speed)	mm/s	100	100	100	100	100	100	100	100
Z Axis (Speed)	mm/s	600	600	600	600	600	600	600	600
Additional Informations									
Weight	kg	7800	8900	10400	6800	8900	10200	11.500	14.000
Oil Tank Capacity	Lt.	125	125	220	125	125	125	220	220
Motor Power	kW	2x3,9	2x3,9	2x 7,7	2x3,9	2x3,9	2x3,9	2x 7,7	2x 7,7
Sliding Front support arms	pcs.	2	2	2	2	2	2	2	2

- Bending speeds above 10 mm/s are used only in robotic applications due to "CE Norms".
- See the side page for measurement details.
- Specifications may change without notice.

Hybrid System

Servo hydraulic press brakes, which are used for precise bending of metal plates are equipped with variable speed drives for energy efficiency and high productivity. With the use of intelligent drives and optimal set-point values for torque and speed of rotation, the motor-pump system provides performance tailored to the needs of each phase of the cycle.

The higher the proportion of partial-load operation, the greater the savings potential, so only the power for the movement of masses and bending during the cycle is consumed. The components required for servo hydraulic drive are configured for specific requirements according to the modular design principle. Additionally there are various possibilities to extend the system with tool clamping and/or crowning. Servo hydraulic systems are part of the strategy for the energy reduction of machines and systems.

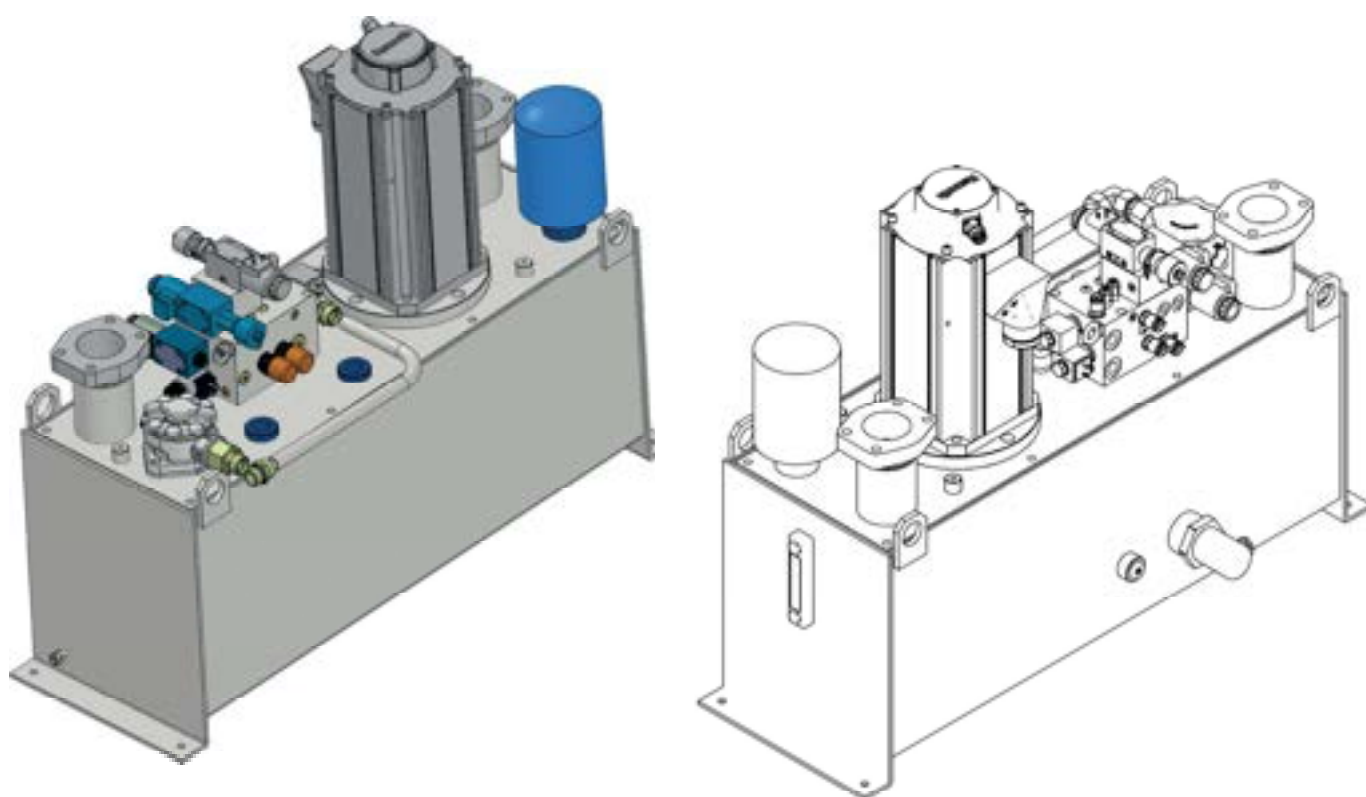

- Fast:** Increased performance up to 35% by reducing the cycle time
- Precise:** Up to 0,005 mm positioning accuracy
- Efficient:** Improving energy efficiency up to 60 % compared to conventional systems and electromechanical solutions
- Flexible:** Strokes up to 400 mm realizable
- Reliable:** Minimal risk of leakage
- Less Noise:** Noise reduction of up to 10 dB(A) in hydraulic power units
- Compatible:** Simple integration into the CNC
- Cost optimized:** Less installation and service expenses; servo drive
- Environmentally friendly:** Considerably reduced oil volume
- Less Oil:** Small tanks

Advantages of the Hybrid Press Brake

Data per axis	Unit	Hybrid control
Volume flow	L/min	max. 22,5-36,5
Operating pressure	bar	max. 320
Pressing Force	kN	max. 550-850
Working Stroke	mm	max. 400
Rapid Speed	mm/s	max. 200
Working Speed	mm/s	max. 10-15W
Positioning Accuracy (depending on the used measuring system)	mm	0,005
Drive Power (standard)	kW	6-10,2
Small Oil Volume	L	34,5 - 55

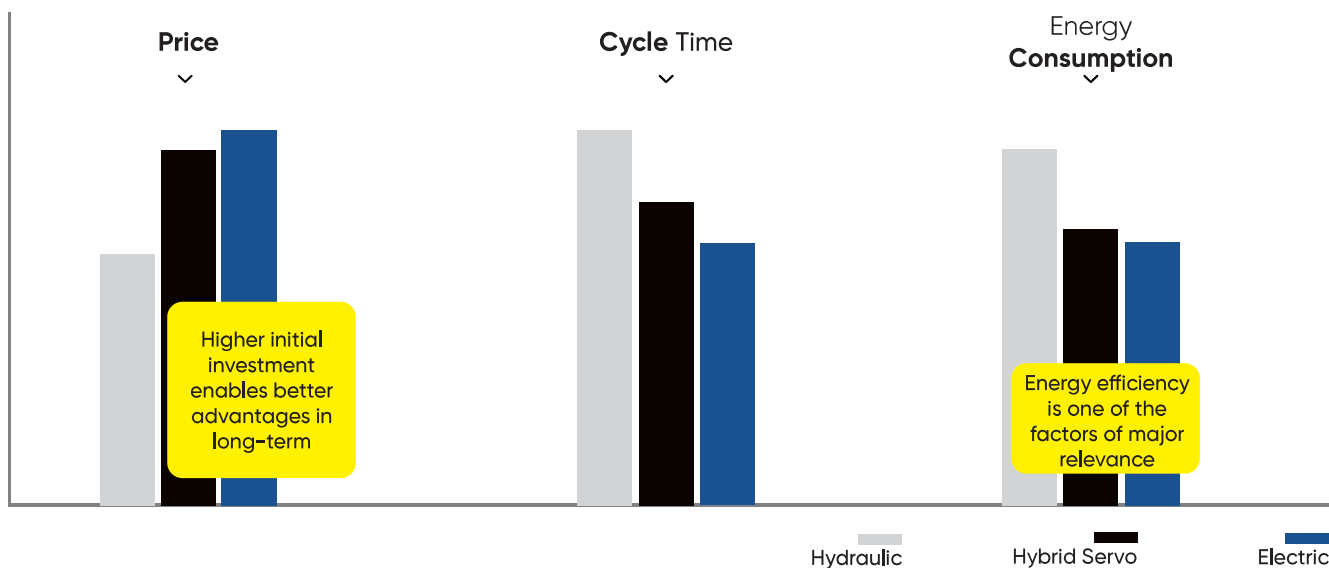



iBend

Introducing our advanced belt driven servo press brake, featuring dual synchronous servo motors and energy-efficient springs for superior performance. The innovative O-Type body system ensures precision and prevents deformation, delivering impeccable bending results for low to medium force applications.

Unlike other belt driven press brakes, our machines are equipped with anti-deflection system to eliminate the deflection of table and gives more precise angle throughout the bend length.

Additionally our combined solution of safety with laser beams and light barriers gives a unique solution for high productivity and less idle time for all parts.



MVD Instagram

Be the winner
of every day

www.mvd.com.tr

BELT DRIVEN

Servo Press Brake



Short Cycle Time

High Productivity

Less Energy

Less Noise

No Oil



iBend

Belt Driven Servo Press Brake

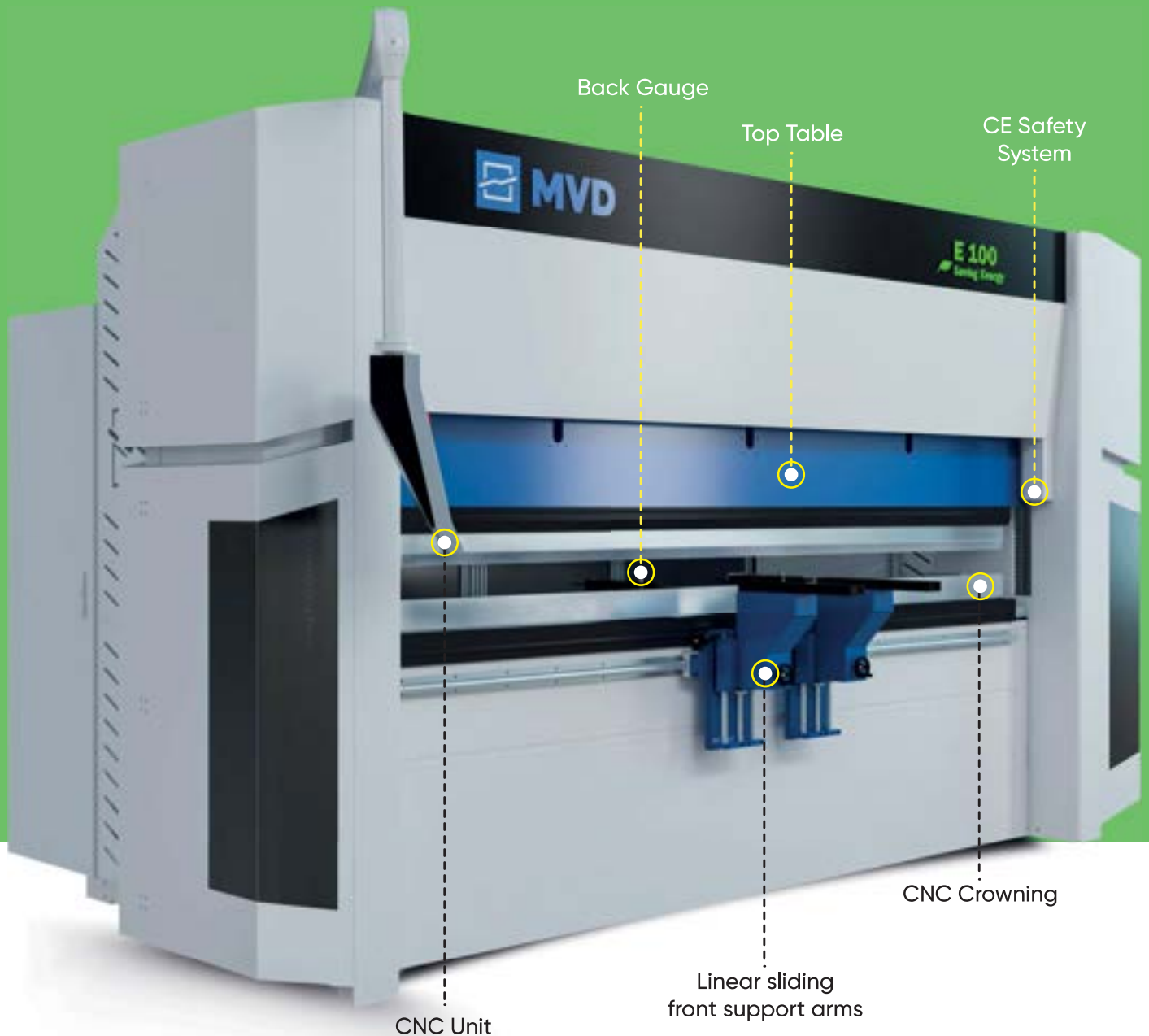

iBend / Belt Driven Servo Press Brake



Standart Features

- Y1, Y2, X, R - 4 Axis CNC
- **Control Unit:** ESA S830
- **Stroke:** 210 – 310 mm
- **Throat Depth:** 410 mm
- **Back gauge:** Servo motorised X+R : Accuracy ± 0.03 mm | X: 750 mm | R: 250 mm
- **Back gauge finger:** 2x pcs, 3x stages
- **Top tool holder:** Promecam type quick clamping
- **Bottom tour holder:** Narrow specific MVD (European type)
- **Top tool:** Standard (H: 67 mm, 85°, R: 0.8 mm)
- **Bottom tool:** Standard (60x60 mm, 4 V die (16/22/35/50 in mm), 85°, H: 60 mm)
- **Linear scale:** GMI optic linear Scales (0.005 mm untied)
- Led lighting
- Sliding front support system
- Double switch pedal

Optional Features

- **Recommended Control Units:** Delem, ESA, Cybelelec or Step
- **Crowning System:** Original WILA or MVD wedge
- **Front safety System:** AKAS II, AKAS LC5M or DSP
- **Backgauge:** MVD or UNIMEC (Gauge options Z1, Z2, X5, ATFL)
- **Beding follower arm:** MVD or UNIMEC
- **Hydraulic top and bottom die clamping:** WILA or Roller
- Bending laser line
- Laser angle measurement system
- Additional back gauge fingers

Advantages



Bending processes:
30 % Shorter



More excellent
bend results



Lower maintenance and
production costs



Less
Noise



No
Oil



Less energy
consumption up to 50 %

iBend

Belt Driven Servo Press Brake

Recommended Control Units

esa



S840, S840W, S860W, S875W

Delem



DA58Tx, DA66S, DA69S

CYBELEC



VisiTouch Pac, CybTouch 15

**STEP
AUTOMATION**



Rock 22+, Rock 17+, Rock 15+

*Screens are representational and may differ from what is shown visually.



iBend / Belt Driven Servo Press Brake

BE THE WINNER OF EVERY DAY



Standard
X + R Axis Back Gauge



Standard
Quick Clamping



Standard
GVI Optic Linear Scales



Technical Specifications

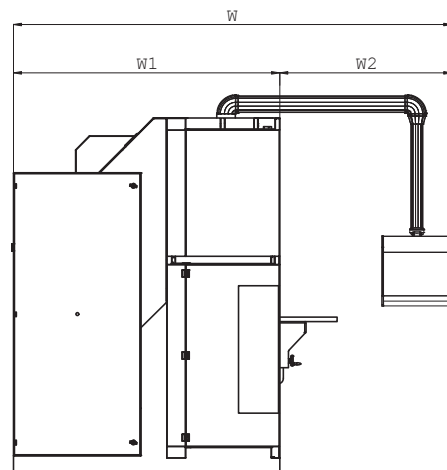
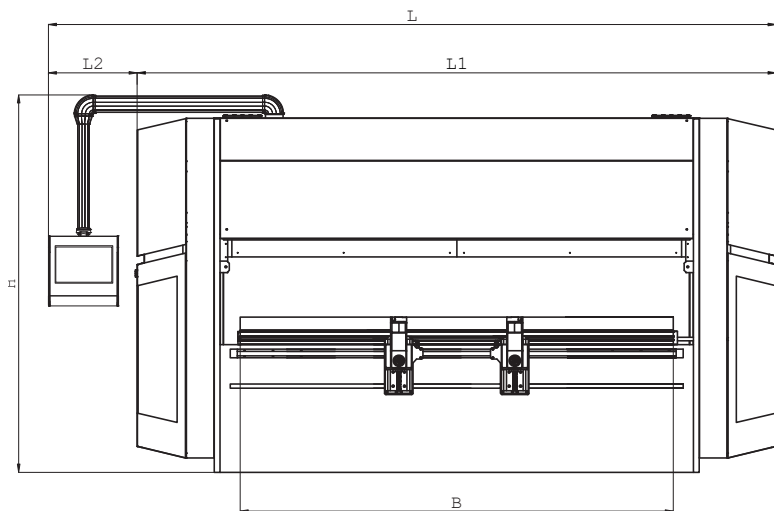

Throat
"O"-Type

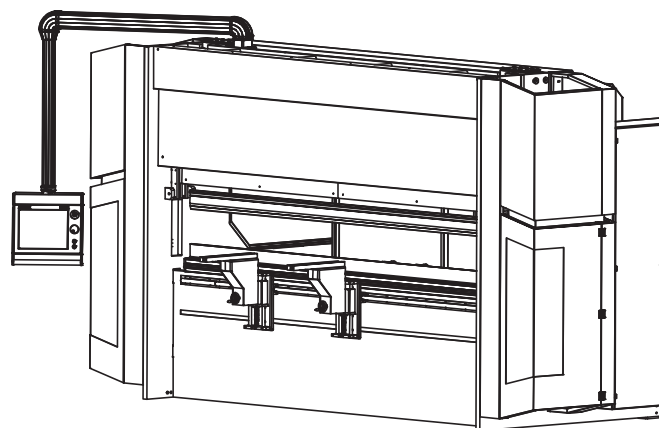
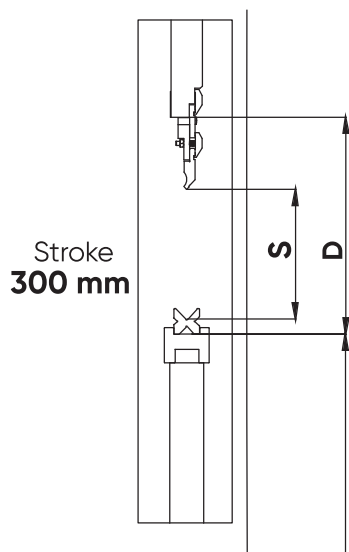

Belt Driven Servo Press Brake		Belt Driven						
General Features	Unit	E80	E100	E130	E130	E160	E160	E200
Bending Force	Ton	80	100	130	130	160	160	200
Bending Length	mm	2600	3100	3100	4100	3100	4100	4100
Distance between columns	mm	2845	3345	3405	4300	3405	4340	4345
Stroke	mm	260	300	300	300	260	260	260
Throat	mm	O-Type	O-Type	O-Type	O-Type	O-Type	O-Type	O-Type
Daylight	mm	465	515	515	515	465	465	465
Speed								
Ram closing speed	mm/s	90	95	85	75	95	85	70
Bending Speed	mm/s CE Norm	10	10	10	10	10	10	10
Return Speed	mm/s	90	95	85	75	95	85	70
Dimensions								
Length	mm	4100	4600	4700	5700	4750	5750	5800
Width	mm	1950	2000	2000	2000	2100	2100	2100
Height	mm	2650	2650	2650	2650	2700	2700	2800
Table Height	mm	900	900	900	900	900	900	900
Backgauge								
Backgauge stroke of the X-Axis	mm	750	750	750	750	750	750	750
Backgaugefinger	pcs.	2	2	2	2	2	2	2
X Axis (Speed)	mm/s	400	400	400	400	400	400	400
R Axis (Speed)	mm/s	100	100	100	100	100	100	100
Z Axis (Speed)	mm/s	600	600	600	600	600	600	600
Additional Information								
Weight	kg	6.500	7.500	8.000	11.000	9.500	14.300	17.000
Motor Power	kW	2 x 5,50	2 x 5,50	2 x 6,25	2 x 6,25	2 x 11	2 x 11	2 x 11
Sliding Front support arms	pcs.	2	2	2	2	2	2	2

- Bending speeds above 10 mm/s are used only in robotic applications due to "CE Norms".
- See the side page for measurement details.
- Specifications may change without notice.



iBend

The rotational motion from servo motors is transferred to ball screw and nut mechanism. This converts the rotation into a precise downward linear movement of the top beam, generating the bending power required for the application.



MVD Youtube Channel

The fastest
of everyday

www.mvd.com.tr

SCREW DRIVEN

Servo Press Brake



Shortest Cycle Time

High Productivity

Less Energy

Less Noise

No Oil



iBend

Screw Driven Servo Press Brake



iBend / Screw Driven Servo Press Brake



Standart Features

- Y1, Y2, X, R - 4 Axis CNC
- **Control Unit:** ESA S830
- **Stroke:** 210 – 310 mm
- **Throat Depth:** 310 mm
- **Back gauge: Servo motorised X+R :** Accuracy ± 0.03 mm | X: 750 mm | R: 250 mm
- **Back gauge finger:** 2x pcs, 3x stages
- **Top tool holder:** Promecam type quick clamping
- **Bottom tour holder :** Narrow specific MVD (European type)
- **Top tool:** Standard (H: 67 mm, 85°, R: 0.8 mm)
- **Bottom tool:** Standard (60x60 mm, 4 V die (16/22/35/50 in mm), 85°, H: 60 mm)
- **Linear scale:** GIVI optic linear scales (0.005 mm untied)
- Led lighting
- Sliding front support system
- Single switch pedal

Optional Features

- **Recommended Control Units:** Delem, ESA, Cybelec or Step
- **Crowning System:** Original WILA or MVD wedge
- **Front Safety System:** AKAS II, AKAS LC5M or DSP
- Additional back gauge fingers
- **Backgauge:** MVD or UNIMEC (Gauge options Z1, Z2, X5, ATFL)
- **Beding follower arm:** MVD or UNIMEC
- **Hydraulic top and bottom die clamping:** WILA or Rolleri
- Bending laser line
- Laser angle measurement system

Advantages



Bending processes:
35 % Shorter



More excellent
bend results



Lower maintenance and
production costs



No
Noise

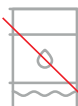

No
Oil



Less energy
consumption up to 60 %

iBend

Screw Driven Servo Press Brake

Recommended Control Units

esa



S840, S840W, S860W, S875W

Delem



DA58Tx, DA66S, DA69S

CYBELEC



VisiTouch Pac, CybTouch 15

**STEP
AUTOMATION**



Rock 22+, Rock 17+, Rock 15+

*Screens are representational and may differ from what is shown visually.

iBend / Screw Driven Servo Press Brake



THE FASTEST OF EVERYDAY



Standard
X + R Axis Back Gauge



Standard
Quick Clamping



Standard
GVI Optic Linear Scales



Technical Specifications

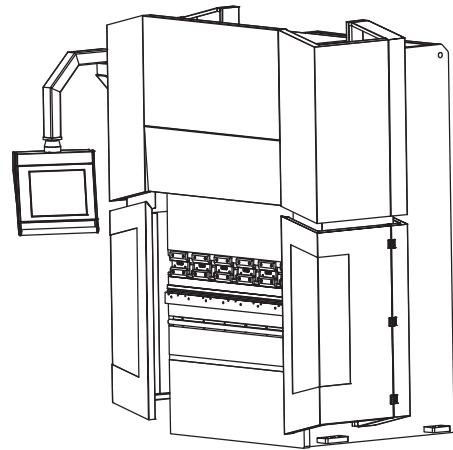
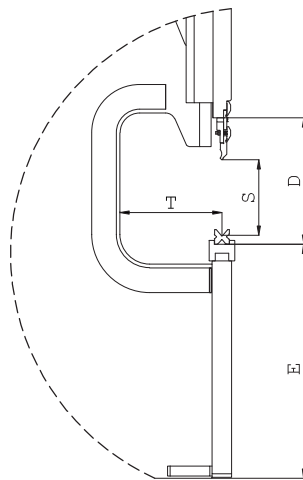
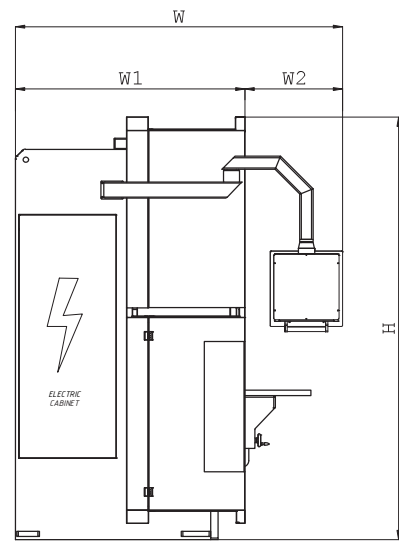
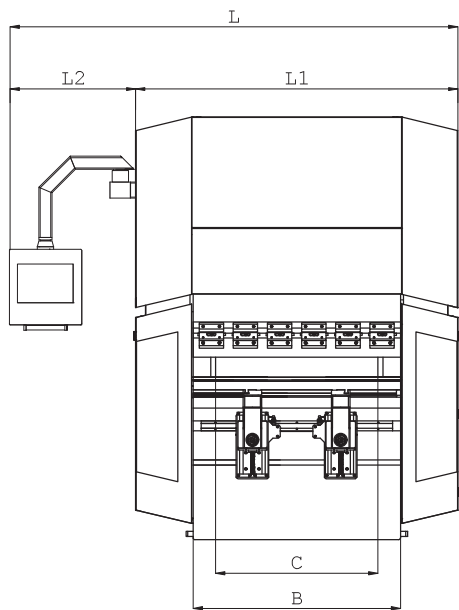

Screw Driven Servo Press Brake		Ball Screw			
General Features	Unit	S20	S40	S60	S100
Bending Force	Ton	20	40	60	100
Bending Length	mm	920	1250	2100	3100
Distance between columns	mm	750	1100	1600	2600
Stroke	mm	210	210	210	300
Throat	mm	300	300	300	300
Daylight	mm	415	415	415	505
Speed					
Ram closing speed	mm/s	250	250	250	250
Bending Speed	mm/s CE Norm	10	10	10	10
Return Speed	mm/s	250	250	250	250
Dimensions					
Length	mm	2300	3000	3600	4600
Width	mm	2200	2300	2300	2500
Height	mm	2750	2750	2750	3350
Table Height	mm	950	950	950	950
Backgauge					
Backgauge stroke of the X-Axis	mm	750	750	750	750
Backgaugefinger	pcs.	2	2	2	2
X Axis (Speed)	mm/s	400	400	400	400
R Axis (Speed)	mm/s	100	100	100	100
Z Axis (Speed)	mm/s	600	600	600	600
Additional Information					
Weight	kg	4000	5000	6000	11500
Motor Power	kW	1 x 12	2 x 12	2 x 12	2 x 15,5
Sliding Front support arms	pcs.	2	2	2	2

- Bending speeds above 10 mm/s are used only in robotic applications due to "CE Norms".
- See the side page for measurement details.
- Specifications may change without notice.

Cost Scenario / Comparison Table

Our servo press brakes are in three different systems, each designed to save energy, increase productivity, improve precision and offer optimum solution for specific needs and power requirements.

The Screw Driven Servo Press Brake offers exceptional productivity and precision performance for tasks requiring low to medium power capacity.

The Belt Driven Servo Press Brake combines speed with versatility, making it ideal for wide range of applications requiring medium power capacity. This model provides flexibility to accommodate various production needs.

The Hybrid Press Brake is faster, more productive and less energy-consuming than a standard hydraulic press brake and is available in a wide capacity range.

The following comparison table highlights the key features and benefits of each model to help select the perfect press brake for your requirements.

Advantages

Lower Energy Consumption



Servo Press Brakes saves up to 60% energy according to hydraulic press brakes.

Increased Speed



Eliminate hydraulic delays and boost efficiency with up to 35% faster performance.

More Ergonomic and Compact Design



Discover comfort and convenience with our ergonomically designed S Series. Its compact design allows easy forklift transport, providing optimal flexibility and efficiency for any workspace.

Faster Bending



Enjoy shorter bending processes with higher acceleration and quicker reaction times, enabling efficient part processing.

Reduce Maintenance and Production Costs



Our fully electric design cuts out hydraulic systems, lowering both maintenance and production costs for efficient, budget-friendly operation.

Quieter Workplace



Experience a quieter workplace with our Servo Press Brake. Its advanced technology reduces noise pollution, creating a better environment for operators while enhancing overall productivity.

Perfect Bend Results



Experience flawless bend results with precise positioning and repeatability, ensuring superior quality and reliability. Reduce costs by eliminating secondary operations.

Fewer Parts and Connections



Go green with our Servo Press Brake—100% electric with no oil needed. Fewer parts mean less environmental impact and lower maintenance costs, saving you money and helping the planet.

Comparison Table

Hydraulic
Press Brake



Hybrid
Press Brake



Belt Driven
Press Brake



Screw Driven
Press Brake



Bending Force	40 - 2000 tons	100 - 2000 tons	80 - 220 tons	40 - 100 tons
Bending Length	1250 - 8100 mm	1250 - 8100 mm	2600 - 4100 mm	1250 - 3100 mm
Energy Consumption	Middle	40 % Less	50 % Less	60 % Less
Maintenance Requirement	Periodic	Periodic	Rarely	Rarely
Maintenance Cost	Low	Lower	Lower	Lower
Positioning Accuracy	High	Higher	Higher	Higher
Machine Noise	Middle	Low	Low	Low
Pump Noise	Yes	Low	None	None
Environmental Pollution	Normal	Low	None	None
Heat Generation	High	Low	None	None
Remote Connection	Yes	Yes	Yes	Yes
System Hardware	Complex	Compact	Compact	Compact

Return on Investment (ROI)

Hydraulic Press Brake vs. Hybrid Servo Press Brake



C320-4100



H320-4100

Sample Calculation		Hydraulic Press Brake C320-4100	Servo Hybrid Press Brake H320-4100	
		Bend [Qty]	Bend [Qty]	Difference
Daily	4 Hours	960	1150	190
Monthly	20 Days	19.200	23.000	3.800
Annual	240 Days	230.400	276.000	45.600
Total		57.600,00 €	69.000,00 €	11.400,00 €
Maintenance	Annual	3.000,00 €	1.000,00 €	2.000,00 €

+ Energy Saving 40 %

Return on Investment = Profit per bend + Maintenance Cost

ROI = 11.400,00 € + 2.000,00 € = 13.400,00 €

In addition, operator costs can be reduced by up to 35% for the same bending quantities, allowing for more efficient work. Another significant advantage is the reduction in energy consumption by up to 40%.

Worked for illustration purposes. Based on ideal working situation.

Per minute: 4 Bends

Daily: 4 hours of work

Monthly: 20 days of work

Profit per bend [0.25 €]

Return on Investment (ROI)

Hydraulic Press Brake vs. Belt Driven Servo Press Brake

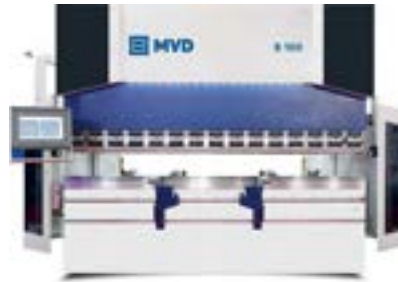

B100-3100



E100-3100

+ Energy Saving 50 %

Sample Calculation		Hydraulic Press Brake B100-3100	Servo Belt Driven Press Brake E100-3100	
		Bend [Qty]	Bend [Qty]	Difference
Daily	4 Hours	960	1150	190
Monthly	20 Days	19.200	23.000	3.800
Annual	240 Days	230.400	276.000	45.600
Total		57.600,00 €	69.000,00 €	11.400,00 €
Maintenance	Annual	3.000,00 €	1.000,00 €	2.000,00 €

Return on Investment = Profit per bend + Maintenance Cost

ROI = 11.400,00 € + 2.000,00 € = 13.400,00 €

In addition, operator costs can be reduced by up to 30% for the same bending quantities, allowing for more efficient work. Another significant advantage is the reduction in energy consumption by up to 50%.

Worked for illustration purposes. Based on ideal working situation.

Per minute: 4 Bends

Daily: 4 hours of work

Monthly: 20 days of work

Profit per bend [0.25 €]

Return on Investment (ROI)

Hydraulic Press Brake vs. Screw Driven Servo Press Brake



B60-2100



S60-2100

Sample Calculation		Hydraulic Press Brake B60-2100	Servo Screw Driven Press Brake S60-2100	
		Bend [Qty]	Bend [Qty]	Difference
Daily	4 Hours	960	1248	288
Monthly	20 Days	19.200	25.960	5.760
Annual	240 Days	230.400	299.520	69.120
Total		57.600,00 €	74.880,00 €	17.280,00 €
Maintenance	Annual	3.000,00 €	1.000,00 €	2.000,00 €

+ Energy Saving 60 %

Return on Investment = Profit per bend + Maintenance Cost

ROI = 17.280,00 € + 2.000,00 € = 19.280,00 €

In addition, operator costs can be reduced by up to 30% for the same bending quantities, allowing for more efficient work. Another significant advantage is the reduction in energy consumption by up to 60%.

Worked for illustration purposes. Based on ideal working situation.

Per minute: 4 Bends

Daily: 4 hours of work

Monthly: 20 days of work

Profit per bend [0.25 €]

General Features

In the world of sheet metalworking, each component plays a critical role in achieving optimal performance and precision. From the robust body structure and advanced CNC units to the versatile front support arms, die holders and tools, every section provides detailed insights into features that enhance operational excellence. Additionally, we cover the back gauge, safety systems, and CNC crowning solutions, ensuring you have all the information needed to make decisions for your metalworking needs.

DSP LASER - AP - T

with 100W max. 0.2s



P.31.25.208
P.31.25.208
P.31.25.208

New Generation Electric Servo Press Brake



Body Structure

Experience high precision with our robust monoblock body and versatile O-Type or C-Type frame options. Our compact design ensures quick installation and easy adaptation, seamlessly integrating into your mass production line.

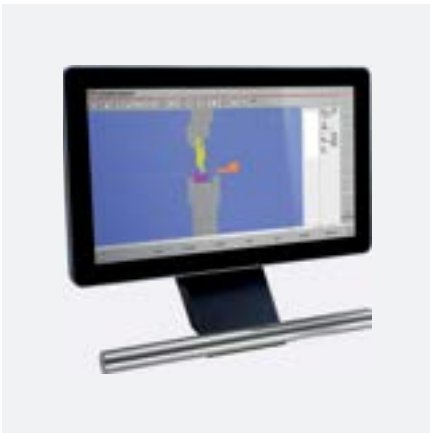

CNC Unit

- ESA S 830 Controller (Standard)
- 10" colour touchscreen
- Automatic bending sequence
- Easy-to-program 2D graphics display
- Up to 4 Axis (Y1,Y2, X and R)

Other recommended controllers:

ESA S840, S840W, S860W **(Optional)**

Delem DA53Tx, DA58Tx, DA66S **(Optional)**



Front Support Arms / Work Table

Benefit from adjustable front support arms and a flexible linear guide system for easy positioning. Our foldable front table option accommodates both standing and seated operation for added comfort and versatility (Optional)



Die Holders and Tools

European-type tool and die holders ensure compatibility and ease of use (Standard)

For enhanced flexibility, optional WILA mechanical, pneumatic, and hydraulic die holder systems are available (Optional)



Back Gauge

MVD X+R Back Gauge offers reliable 2-axis positioning for easy part machining (Standard)

Upgrade to the optional MVD X+R+Z1+Z2 Back Gauge with servo motors for precise, programmable control on additional axes, ensuring rapid and accurate positioning (Optional)



Safety System

Designed to European CE standards, our safety system features advanced safety innovations for enhanced protection. You can choose for your needs one of the famous safety system models from Fiessler GmbH AKAS or Nuova Electronics DSP.



CNC Crowning

Our crowning system corrects table yawing in real time using advanced sensors, ensuring accurate bending angles. Motorized crowning provides precise and consistent results, especially for long parts over 3.000 mm.

Control Units

Reliability and precision are key to operational efficiency in advanced manufacturing processes. The control units used in press brakes are designed to meet these needs at the highest level. The screen models offered by ESA, Delem, Cybelec, and Step provide superior performance, ease of use, and long-lasting reliability for all types of metalworking applications.



S 875W



S 860W



S 840

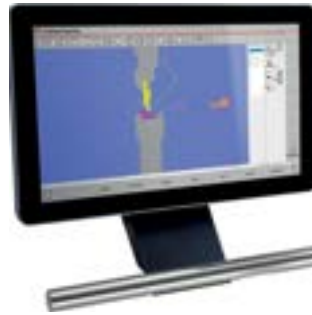

S 830

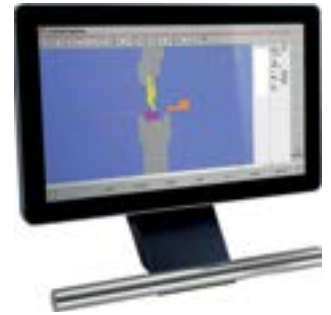

ESA Control Units	ESA S875W	ESA S860W	ESA S840	ESA S830
Axis	4-128	4-8	4-6	3-4
Screen	21"	18,6"	15"	10"
2D Graphic View	+	+	+	+
2D Drawing	+	+	+	+
3D Graphic View	+	+	-	-
3D Graphical Programming	+	opt.	-	-
3D Drawing	+	opt.	-	-
Automatic Bending Sequence And Collision Check	+	+	+	+
Crowning Calculation	+	+	+	+
Harddisk	20 GB+	20 GB+		
Access	Remote	Remote	Remote	Remote
Operating System	Windows	Windows	-	-
Transfer DXF Files	+	opt.	-	-
Tool Management	+	+	+	+
Angle Measurement	+	+	-	-
Angle Correction	+	+	+	+
Offline Software	3D	2D	2D	2D
Industry 4.0	+	+	-	-

Delem

DA-69S



DA-66S



DA-58Tx



DA-53Tx



DELEM Control Units	DA69S	DA66S	DA58Tx	DA53Tx
Axis	4-12	4-8	3-6	3-4
Screen	24"	24"	18,6"	15"
2D Graphic View	+	+	+	+
2D Drawing	+	+	+	+
3D Graphic View	+	+	-	-
3D Graphical Programming	+	-	-	-
3D Drawing	+	-	-	-
Automatic Bending Sequence And Collision Check	+	+	+	Semi
Crowning Calculation	+	+	+	+
Harddisk	4 GB	4 GB	1 GB	1 GB
Access	Remote	Remote	Remote	Remote
Operating System	Linux	Linux	Linux	Linux
Transfer DXF Files	+	opt.	-	-
Tool Management	+	+	+	+
Angle Measurement	+	+	-	-
Angle Correction	+	+	+	+
Offline Software	3D	2D	2D	2D
Additional Features	opt.	opt.	-	-
Industry 4.0	+	+	-	-



VisiTouch 24 MX

VisiTouch Pac

CybTouch 15

CybTouch 12



CYBELEC Control Units	VisiTouch 24 MX	VisiTouch Pac	CybTouch 15	CybTouch 12
Axis	4-24	4-12	4-6	3-4
Screen	24"	19"	15"	12"
2D Graphic View	+	+	+	+
2D Drawing	+	+	+	+
3D Graphic View	+	+	-	-
3D Graphical Programming	+	-	-	-
3D Drawing	+	-	-	-
Automatic Bending Sequence And Collision Check	+	+	+	opt.
Crowning Calculation	+	+	+	opt.
Access	Remote	Remote	Remote	Remote
Operating System	Windows	Windows	-	-
Transfer DXF Files	+	opt.	-	-
Tool Management	+	+	+	+
Angle Measurement	+	-	-	-
Angle Correction	+	+	+	+
Offline Software	3D VisiTouch MX	VisiTouch MX	CybTouch (2D)	CybTouch (2D)
Industry 4.0	+	+	-	-



ROCK 22+ DUAL



ROCK 17+



ROCK 15+



ROCK 12+



STEP Control Units	Rock RK22+	Rock RK17+	Rock RK15+	Rock RK12+
Axis	3-12	3-12	3-8	3-6
Screen	22"	17"	15,6"	12"
2D Graphic View	+	+	+	+
2D Drawing	+	+	+	+
3D Graphic View	+	+	+	opt.
3D Graphical Programming	+	+	+	-
3D Drawing	+	+	+	-
Automatic Bending Sequence And Collision Check	+	+	+	+
Crowning Calculation	+	+	+	+
Access	Remote	Remote	Remote	Remote
Operating System	Linux	Linux	Linux	Linux
Transfer DXF Files	IGES/Step Tool and Part Import	+	-	-
Tool Management	+	+	+	+
Angle Measurement	+	+	-	-
Angle Correction	+	+	+	+
Offline Software	3D	3D	3D	2D
Industry 4.0	+	+	+	+

Top Punch / Bottom Die Holders

Experience maximum efficiency with our top punch holders—offering precision, positioning, and alignment all in one. Benefit from top speed, safety, and flexible tool changes whether horizontal or vertical.



NEW STANDARD[®] PRO WILA

NEW STANDARD[®] PRO WILA

Top Punch Holders



Quick Promecam Punch Clamping

European style quick clamping Promecam

- Punch holder
- Provides easy tool change
 - Provides time saving
 - Safe and secure against tools falling



Wila NSCL Hydraulic Punch Clamping

Set a new benchmark for bending with the NEW STANDARD PRO. Ideal for applications requiring quality and productivity without stringent demands, this WILA range offers a full suite of tools designed for limited working heights. The intelligent tool holder and tool combination ensures flawless, even bending results.

- Working height = 80 mm, width = 88 mm.
- Option: Smart Tool Locator® (STL)
- Hydraulic compression (max. 50 bar), oil inlet \varnothing 10 mm, material = C45 not hardened. Allows horizontal and vertical tool changes.
- Max. load resistance: 180 - 250 t/m
- Weight: 32 kg/m



Bottom Die Holders



Narrow European Die Clamping

- Comes with a special bottom plate, available in 70 mm or 90 mm based on tonnage.
- T-Channel can be adjusted to accommodate various tools.



Wila NSCR Hydraulic Die Clamping

Set a new benchmark for bending with the NEW STANDARD PRO. Ideal for applications requiring quality and productivity without stringent demands, this WILA range offers a full suite of tools designed for limited working heights. The intelligent tool holder and tool combination ensures flawless, even bending results.

- CNC motor crowning
- Working height = 95 mm, width = 98 mm.
- Hydraulic compression (max. 50 bar), oil inlet \varnothing 10 mm, material C45 not hardened.
- Allows horizontal tool changes
- Max. strength resistance: 220 t/m
- Weight: 66 kg/m



Back Gauge Options

Achieve precise bending with our Back Gauge System, designed for single-step use and multi-step complex parts with up to 8 axes options. Featuring linear bearings, servo motors, and a ball screw shaft, the MVD back gauge ensures high-speed and perfect bending. Its 3-stage back gauge fingers and pneumatic extension arms enable easy handling of any type of bending.



Back Gauge Options

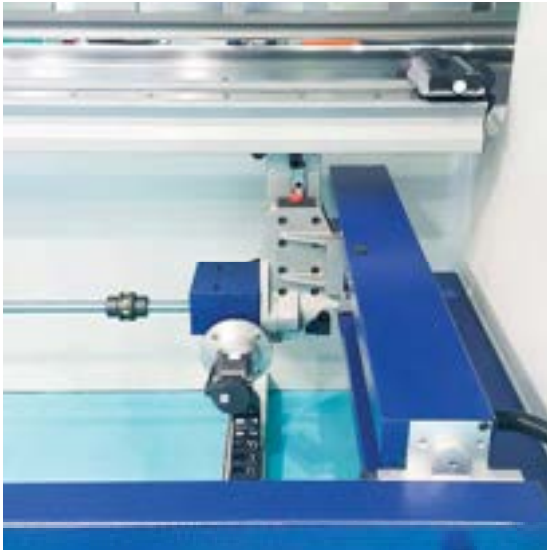

X + R (2 Axis) Back Gauge

MVD Servo Motorized Back Gauge, Automatically moving of X- and R-Axis

- X-Axis: distance X: 750 mm | Speed: 400 mm/s | Precision: +/- 0.05 mm
 - R-Axis: maximum height distance R: 250 mm | Speed: 100 mm/s | Precision: +/- 0.05 mm
 - Manual movement of the back gauge fingers on the Z-Axis
 - Strong steel body construction
 - Hardened ball screw shaft and hardened linear guides
 - Optional: X-Axis distance can be extended up to 1000 mm

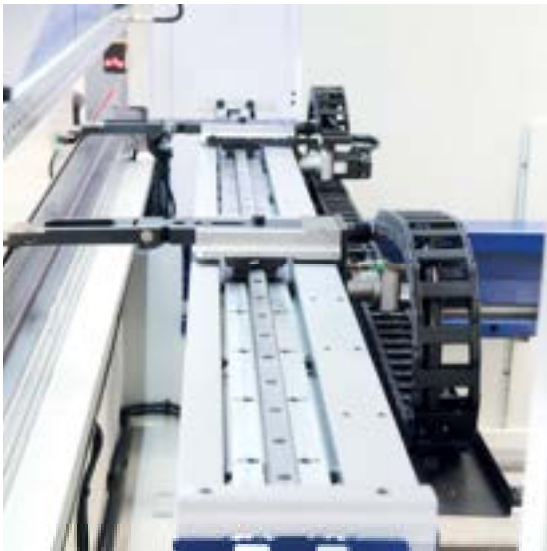

X, R, Z1, Z2 Axis (4 Axis) Back Gauge

MVD Servo Motorized Back Gauge, Automatically moving of X, R and Z1-Z2-Axes

- X-Axis: distance X: 750 mm | Speed: 400 mm/s | Precision: +/- 0.05 mm
 - R-Axis: maximum height distance R: 250 mm | Speed: 100 mm/s | Precision: +/- 0.05 mm
 - Z-Axis: Z1 and Z2-Axes Speed: 600 mm/s | Precision: +/- 0.20 mm
- Strong steel body construction
- Hardened ball screw shaft and hardened linear guides
- Optional: X-Axis distance can be extended up to 1000 mm





X, R, Z1, Z2+X5 Axis (5 Axis) Back Gauge

MVD Servo Motorized Back Gauge, Automatically moving of X, R and Z1-Z2-Axes

- X-Axis: distance X: 750 mm | Speed: 400 mm/s | Precision: ± 0.05 mm
 - R-Axis: maximum height distance R: 250 mm | Speed: 100 mm/s | Precision: ± 0.05 mm
 - Z-Axis: Z1 and Z2-Axes Speed: 600 mm/s | Precision : ± 0.20 mm
 - X5-Axis: Moving automatically with servo motor Travel distance X5: ± 100 mm | Speed: 250 mm/s | Precision: ± 0.05
- Strong steel body construction
- Hardened ball screw shaft and hardened linear guides
- Optional: X-Axis distance can be extended up to 1000 mm



X1, X2, R1, R2, Z1, Z2 Axis (6 Axis) Back Gauge

MVD Servo Motorized Back Gauge, Automatically moving of X1, X2, R1, R2, Z1, Z2

- X-Axis: distance X: 750 mm | Speed: 400 mm/s | Precision: ± 0.05 mm
 - R-Axis: maximum height distance R: 250 mm | Speed: 100 mm/s | Precision: ± 0.05 mm
 - Axis: Z1 and Z2-Axes Speed: 600 mm/s | Precision : ± 0.20 m
- Strong steel body construction
- Hardened ball screw shaft and hardened linear guides
- Optional: X-Axis distance can be extended up to 1000 mm



Other Options



Laser Check

Auto Angle Measurement System



Bending Line

Bending Line Laser



Cabin Cooler

Air-Conditioned Cooling System



Motorized

Crowning System



Pneumatic
Rear Sheet Metal Support Arms



AP01 / AP02
Front Sheet Metal Support Arms



Mitutoyo
Angle Measurement Device

Safety Options



AKAS II Laser Front Safety

AKAS® II Press brake safety laser system (Manual)

It is a finger protection system for laser optical front guards, press brakes, mounted next to the upper table, at the level of the upper molds.

- **Max. working distance:** 8 m
- **Speed change point:** up to 13 mm



AKAS 5 Laser Front Safety

AKAS® LC5M Press brake safety laser system (Motorized)

It is a finger protection system for laser optical front guards, press brakes, mounted next to the upper table, at the level of the upper molds.

- **Max. working distance:** 8 m
- **Speed change point:** up to 0 mm



AKAS LC5M Laser Front Safety

AKAS® LC5M Press brake safety laser system

It is a finger protection system for laser optical front guards, press brakes, mounted next to the upper table, at the level of the upper molds.

- **Max. working distance:** 8 m
- **Speed change point:** up to 0 mm



DSP Laser Front Safety

DSP

DSP Laser safety device protects the press brake operator from the danger of crushing between the moving and fixed part of the machine. With multi laser beams.

- **Max. working distance:** 8 m
- **Speed change point:** up to 2 mm



Rear Safety
Light Curtain



Rear Safety
Laser Beams



Akas FPSC
non CE Laser Front Safety

Top Punch

1260



85° / H: 66,6 / R: 0,8 /
Max T/m: 100

1281



85° / H: 104,65/ R: 0,8 /
Max T/m: 100

1172



85° / H: 104,65/ R: 0,8 /
Max T/m: 50

1309

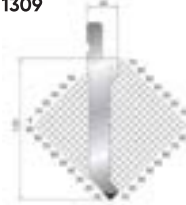

85° / H: 120/ R: 0,8
/ Max T/m: 70

1196



24° / H: 128/ R: 0,6 /
Max T/m: 80

1036



H: 67 / Max T/m: 100

1055

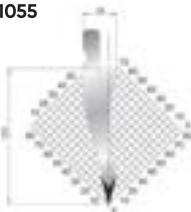

30° / H: 105 / R: 0,5 /
Max T/m: 50

1262

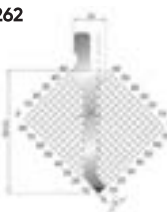

88° / H: 99,35/ R: 0,25
/ Max T/m: 50

1061

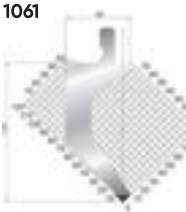

88° / H: 120/ R: 0,8
/ Max T/m: 50

3177



24° / H: 80 / R: 10,1 /
Max T/m: 50

1107



R: 12,5

1270

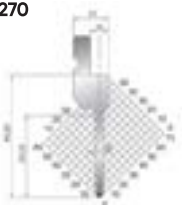

88° / H: 94,35/ R: 0,25
/ Max T/m: 50

805 mm Pieced Top Die Set



Bottom Die

2067

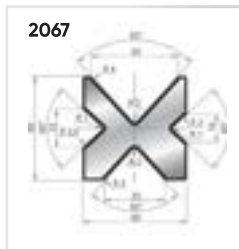

88° / H: 94,35/ R: 0,25 /
Max T/m: 50

2025



80° / H: 95 / V: 100 /
Max T/m: 120

3015

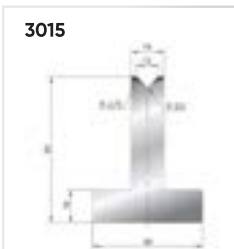

88° / H: 80 / V: 12 /
Max T/m: 100

3055

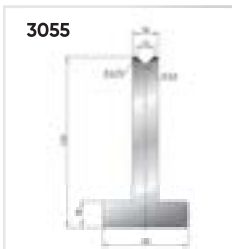

88° / H: 120 / V: 12 /
Max T/m: 100

3076



30° / H: 120/ V: 12 /
Max T/m: 40

805 mm Pieced Bottom Die Set



Bending Table

V(mm)	4	6	8	10	12	16	20	24	30	40	50	60	80	100	120	160
V(inc)	0,157"	0,236"	0,315"	0,394"	0,472"	0,630"	0,787"	0,945"	1,181"	1,575"	1,969"	2,362"	3,150"	3,937"	4,724"	6,299"
mm from outside to outside	2,8	4,2	5,6	7	8,6	11,5	14,4	17	21	29	36	42,4	56,5	71	85	114
ri(mm)	0,6	1	1,2	1,5	1,8	2,4	3	3,6	4,5	6	7,5	9	12	15	18	24

Material thickness (mm)

0,5	4	2																	
1		10	8	5,5	4,5														
1,2		16	12	9	7														
1,5			20	14	11	8	6												
2					22	15	11	9,5											
2,5						25	19	15	11										
3							28	22	17	12									
4								44	22	22,5	17								
5									55	37	29	22							
6										58	42	34							
8											83	65	45	35					
10												110	75	57	45				
12													116	85	68				
14														121	91	68			
15															143	112	79		
16																168	131	90	
18																	172	119	
20																		222	150
25																			254

TONNAGE PER METER

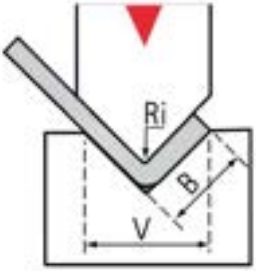

F = $\frac{S^2 \times 2 \times TS}{1.4 \times V}$ = ton / m

TS: Tensile Strength
(Steel 42 kg/mm²)

Top Punch Holders

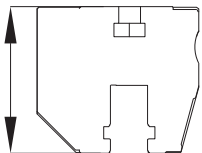

Wila Clamping
NSCL-I-HC/UPB

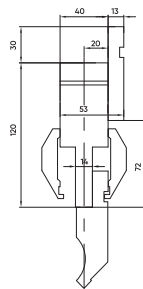

MVD Quick Clamping
Promecam

Bottom Die Holders

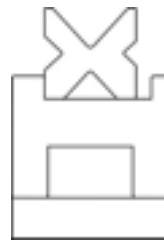

Narrow
Type

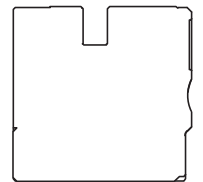

Wila Clamping
NSCR-I-HC/UPB

Our Service

On Time Delivery



With our flexible team, we deliver on time, every time!

Trust



At MVD, trust is a core principle. Experience it in our reliable machines and steadfast cooperation.

After Sales Support



With our dedicated service team, extensive spare parts inventory, and comprehensive operator training, MVD we ensure lasting assurance and support for years to come.

Training



We provide advanced operator training to ensure efficient use of our machines.

Spare Part Service



We will never let you down! Count on us—our spare part service is always available to support you.

Consultancy



Benefit from our industry expertise, we will help you to make the best choice for your needs with our expert consultancy services.

Innovation



We invest in innovation to continually enhance MVD quality.

R&D



MVD is shaping the future with advanced technology development and an experienced R&D team.

Quality



MVD delivers 'World Class' machines, ensuring top-quality solutions for our partners.

Power



With our experience from the past and vision of the future, we are your strongest solution partner for your business.

Productivity



Under our quality assurance, we produce machines designed to boost your productivity.

Design



We meticulously integrate innovative designs into our machines.



Sustainability **Vision**

As MVD Machine, committing to the vision of carbon neutrality under the green agreement, diligently we work to integrate it into all areas of our production.

We support environmentally friendly production worldwide with our iBend servo press brakes which achieve low energy consumption.

Sustainability is a responsibility same like the responsibility of supporting our machines. We do support the nature to leave a cleaner world for future generations.

Take a step with iBend Servo press brake towards a sustainable future!





#greendeal



mvd.com.tr



2024 September

