

OPZIONI OPTIONS

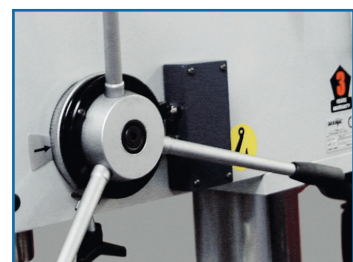

CODE 40024:
Impianto illuminazione a LED a 24 V
24 V LED light



CODE 40002:
Filettatura con teinvertitore
Thread-cutting unit with transformer

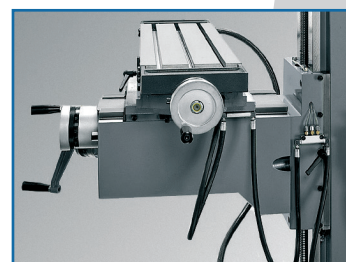

CODE 40007:
Lubrificazione centralizzata
delle guide della tavola (manuale)
Centralized system for guide lubrication
(manual)

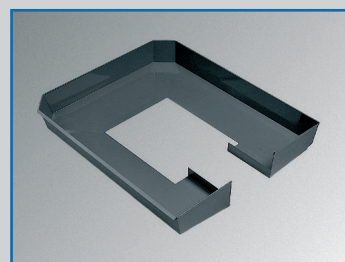

CODE 5355351:
Vaschetta raccogli trucioli per TCS
Chip and drip collecting tray for TCS

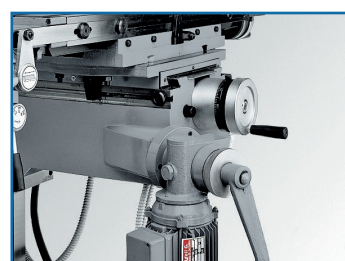

CODE 40006:
Avanzamento rapido verticale
della tavola
Rapid vertical table feed



CODE 40026 POWER:
Avanzamento automatico
longitudinale meccanico della tavola
Mechanical longitudinal cross-table feed

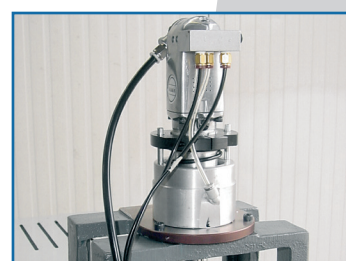

CODE 40097:
Sgancio utensile ISO 40 pneumatico
ISO 40 Spindle shaft with hydraulic lock
and release system



CODE 40008:
Supporto telescopico tavola
Table telescopic support



CODE 40083:
Discesa automatica tramite innesto
elettromagnetico a 24 V c.c.
24 V Dc Electromagnetic automatic
quill-feed



CODE 40001:
Corsa mandrino 230 mm (solo con VS)
230 mm long sleeve (only with VS)



CODE 40020:
Asse mandrino ISO 40 con tirante
(DIN 2080)
ISO 40 spindle including tie-rod
(DIN 2080)

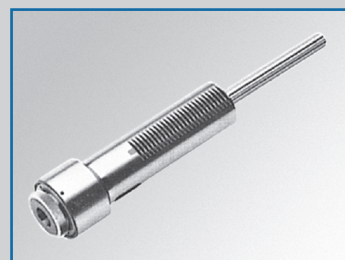

CODE 40037:
Asse mandrino CM4 forato per
passaggio tirante bloccaggio utensile
MT4 Drilled spindle axis for tie rod
(DIN 2080)

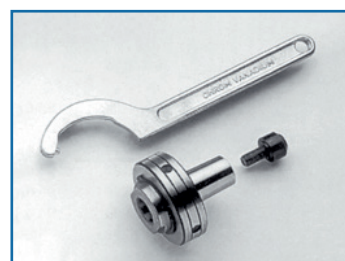

CODE 39000050/60/70:
Cono con ghiera di bloccaggio
per frese a candela, con morse
interno a richiesta 1-2-3
Adaptor with locking ring nut for slot
end-mills MT1 - MT2 - MT3 upon
request

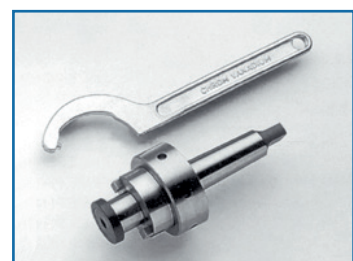

CODE 39000010/20/30/40:
Cono con ghiera di bloccaggio
per frese a spianare, con attacco
a richiesta ø 16-22-27-32.
Adaptor with locking ring nut for
face-mills attachments on request dia.
16-22-27-32



CODE 9460009:
Cassetta con mandrino portapinzette:
ø 4-6-8-10-12-16-20.
Box with MT4 collet-chuck and dia.
4-6-8-10-12-16-20 collets



**CODE 9459210 (CM4)
CODE 9459212 (ISO 40):**
Cassetta completa di coni per frese a
candela, per frese a spianare, mandrino
portapinzette ø 4-20, testa barenatrice ø
70 con attacco CM4 a richiesta attacco
ISO 40.
Box containing taper shanks for end
and face-mills, gripper-carrying spindle
for 4-20 dia. mm drills, 70 dia. mm bo-
ring head with MT4 taper, ISO 40 taper.



MADE IN ITALY



1950

Da oltre 65 anni nel mercato
On the market for over 65 years

> 2.000

Capacità produttiva di oltre 2.000 unità l'anno
Production capacity over 2.000 units per year

> 30

Più di 30 modelli diversi
More than 30 different models

Rivenditore autorizzato / Official dealer:

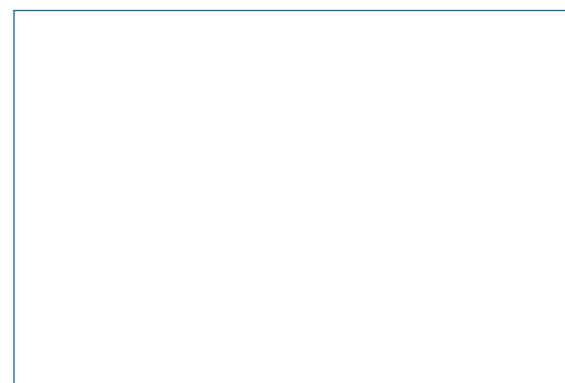

SERRMAC

SERRMAC INTERNATIONAL S.R.L.

Via delle Industrie, 9
33070 POLCENIGO (PN) - Italy
Tel. +39 0434 671021
Fax +39 0434 671031
info@serrmac.it
www.serrmac.it

SERRMAC International si riserva
il diritto di apportare senza alcun
preavviso qualsiasi modifica che
ritenga necessaria.

The Company SERRMAC Inter-
national has the right to make the
needed modifications without any
notice.

CE

MADE IN ITALY

SERRMAC
TECNOLOGIA E QUALITÀ MADE IN ITALY dal 1950

SERIE TCS

Trapani-Fresa / Drilling-Milling Machines



TCS



TCSE

ITA_EN

TCS

**TRAPANO-FRESA
SERIE TCS**
DRILLING-MILLING MACHINE
TCS SERIES

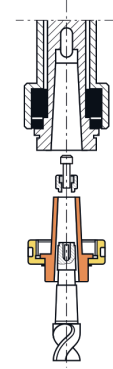

Asse mandrino filettato
per bloccaggio utensile CM4
Threaded quill nose
for tool fitting MT4

STANDARD:
Discesa automatica meccanica
Automatic mechanical quill-feed

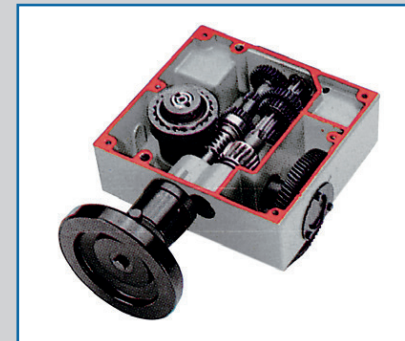

TR: 600 x 345 mm
Tavola rettangolare
Rectangular table with rack



TR

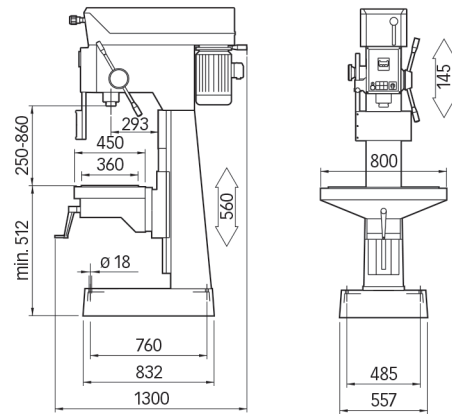

TC

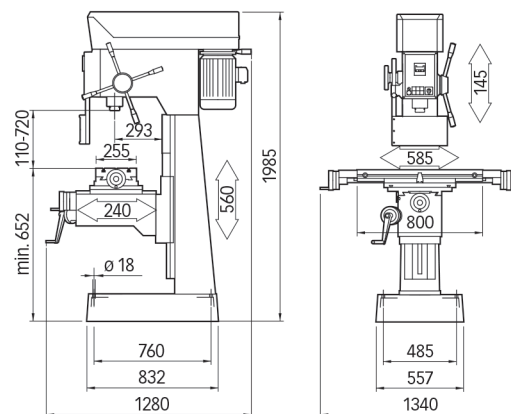

TCSE

**TRAPANO-FRESA SERIE TCS
CON TRASMISSIONE AD ALTO RENDIMENTO
E VARIATORE DI GIRI ELETTRONICO MEDIANTE
INVERTER VETTORIALE**

TCS SERIES DRILLING-MILLING MACHINE
WITH HIGH PERFORMANCE TRANSMISSION
AND VARIABLE ELECTRONIC SPEED DRIVES
BY MEANS OF INVERTERS

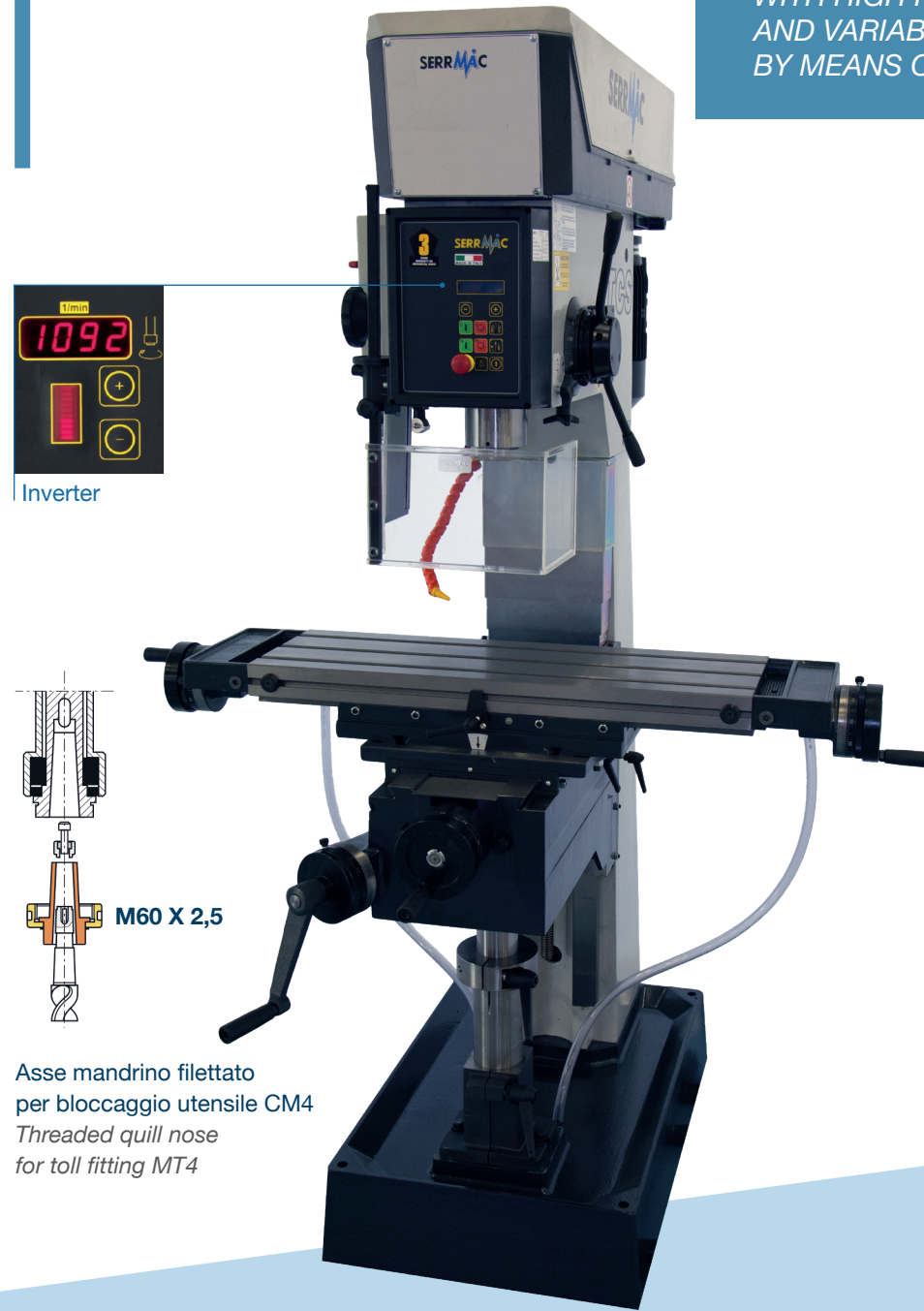

Inverter

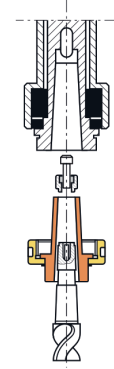

Asse mandrino filettato
per bloccaggio utensile CM4
Threaded quill nose
for tool fitting MT4

STANDARD:
Fronte digitale
Digital Front



TR: 600 x 345 mm
Tavola rettangolare
Rectangular table with rack



TR

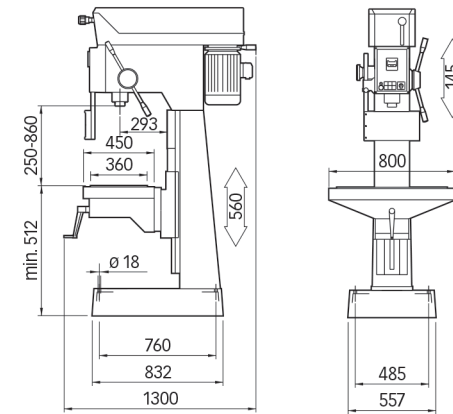

TC

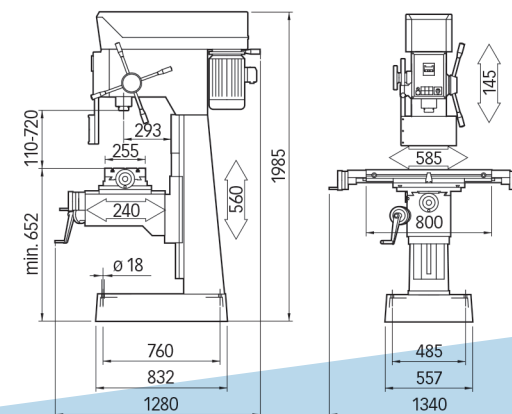

TECHNICAL DATA

		TCS			TCSE
Capacità di foratura su acciaio R50 Drilling capacity on R50 steel	mm	Ø 50			Ø 50
Capacità di maschiatura su acciaio R50 Tapping capacity on R50 steel	mm	M26			M26
Cono mandrino Spindle - intake		CM4			CM4
Corsa mandrino Quill - stroke	mm	145			145
Diametro canotto mandrino Spindle - quill diameter	mm	72			72
Discesa automatica Automatic mechanical quill - feed	mm / giro	3 VELOCITÀ / 3 SPEED: 0.05 - 0.1 - 0.2 mm/giro - mm/round			
Discesa automatica con frizione elettromagnetica Electro - magnetic automatical quill - feed	mm / giro	3 VELOCITÀ / 3 SPEED: 0.05 - 0.1 - 0.2 mm/giro - mm/round			
Colonna Column		Prismatica / Prismatic			
Tavola Table		TR - TC			TR - TC
Trasmissione Transmission		VS	VR	CI	Inverter
Velocità mandrino Spindle speed	rpm	100 - 1.620	40 - 2.340	50 - 1.300	45 - 2.150
Potenza motore (380 V 50 Hz) Motor Power (380 V 50 Hz)	KW	2.2 - 3	2.2	2.2 - 3	3
Interasse tra 2 cave a "T" (TR) T - slots interaxis between 2 T - slots (TR)	mm	180			180
Interasse tra 3 cave a "T" (TC) T - slots interaxis between 3 T - slots (TC)	mm	80			80
Dimensione cave a "T" T - slots dimensions	mm	14			14
Tavola croce: corsa long. manuale asse X Cross table longitudinal stroke - X axis (manual feed)	mm	585			585
Tavola croce: corsa long. automatica asse X Cross table longitudinal stroke - X axis (automatic feed)	mm	520			520
Tavola croce: corsa trasversale manuale asse Y Cross table transversal stroke - Y axis (manual feed)	mm	240			240
Dimensioni (h x l x p) a colonna Column model dimensions (h x w x d)	mm	1.986 x 1.340 x 1.280			1.986 x 1.340 x 1.280
Peso Weight	Kg	660 (TR) - 780 (TC)			660 (TR) - 780 (TC)

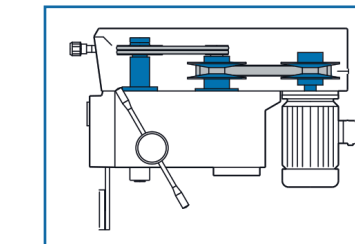

VS: Variatore semplice
Variable speed-drive unit



VS: Variatore semplice
Variable speed-drive unit

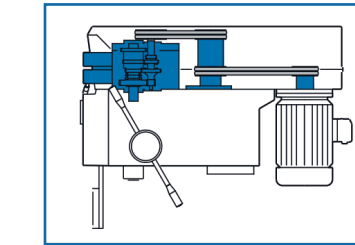

CI: Cambio ingranaggi
Gear box drive-unit

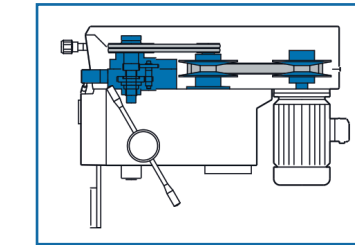

VR: Variatore ritardo
Variable speed-drive unit

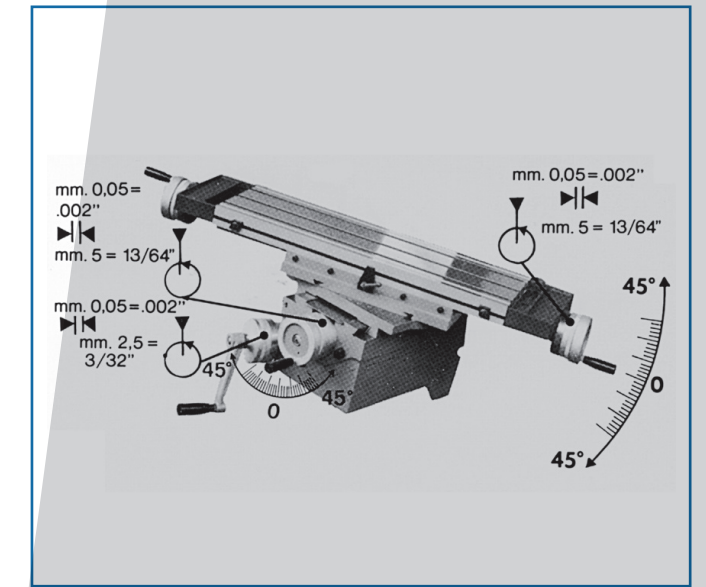

TC: Tavola Croce
Cross table