



Enka Carré Muurwoningen & Pleinwoningen

Woningtype A - Opties

Verkooptekeningen

Datum: 15-4-2020

Bokkers van der Veen Architecten



Algemene symbolen

	vloerhoogte t.o.v. peil
	woningtree
	noordpijl
	garderobe
	maat tussen de pijlen









Bouwkundig

	gevelmetselwerk
	kalkzandsteen
	lichte scheidingswand
	metal-stud wand
	geïsoleerde metalstud wand
	betonwand

veiligheid: brand

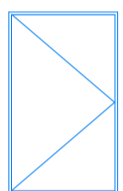
	optische rookmelder conform NEN-2555 (gekoppeld en op het lichtnet aangesloten)
---	---

installatieonderdelen

	MV-box
	vloerverwarmingsverdeler
	vloerverwarming
	radiator
	zonnepaneel
	opstelplaats wasmachine
	opstelplaats wasdroger
	omvormer/elektra meter met werkschakelaar
	afzuigventiel MV

installatieonderdelen

	schel, tbv deurbel
	beldrukker
	wandlichtpunt, standaard: 2100+, badkamer: 1700+
	plafondlichtpunt
	enkelpolige schakelaar, 1050+
	wisselschakelaar, 1050+
	dubbele wandcontactdoos geaard, 300+
	enkele wandcontactdoos geaard, 300+
	enkele wandcontactdoos tbv wasmachine
	enkele wandcontactdoos tbv wasdroger
	enkele wandcontactdoos tbv mechanische ventilatie
	enkele wandcontactdoos tbv verdeler
	centraal aardpunt
	aansluiting thermostaat, 1500+
	aansluiting, co2 sensor, 1500+
	aansluiting data, 300+
	aansluiting, loos, 300+
	aansluiting centrale antenne, 300+
	combinatie; schakelaar/enkele wandcontactdoos, 1050+
	buitenkraan

Renvooi

Datum 15-4-2020

Formaat A3

Maatvoering in mm

AM

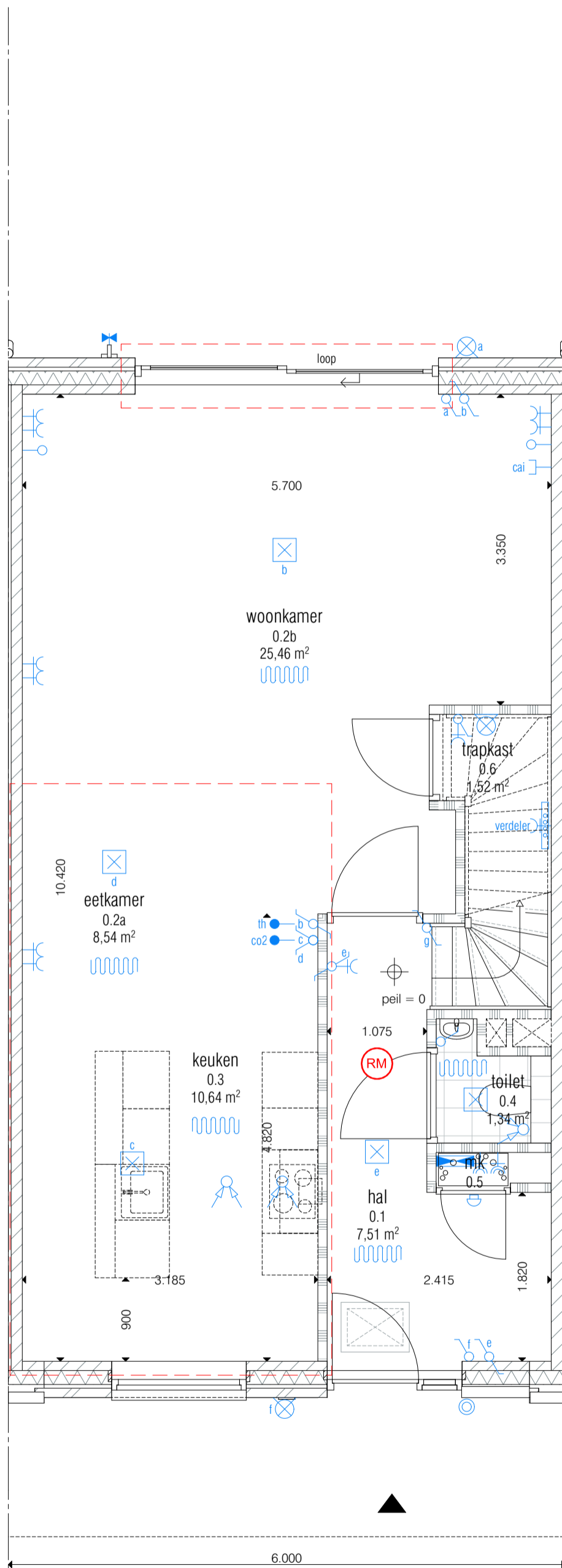

1.020.1.011
optie: houten schuifpui

2.040.1.015
optie: keuken verplaatsen naar voorzijde

Woningtype A

Titel Begane grond
Datum 15-4-2020
Schaal 1:50
Formaat A3

Maatvoering in mm



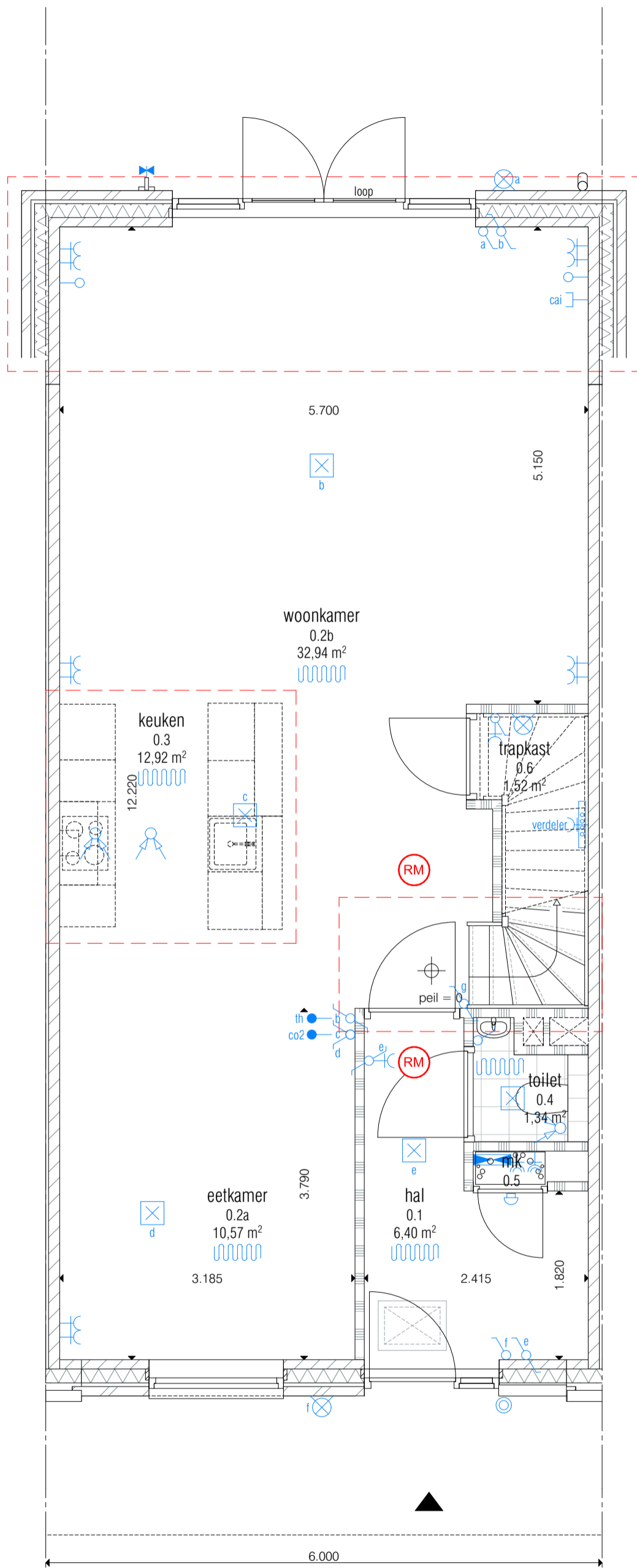

1.010.1.001
optie: uitbouw begane grond 1,8 m

2.040.1.016
optie: keuken verplaatsen thv trapkast

2.040.1.002
optie: trap in woonkamer

Woningtype A

Titel Begane grond
Datum 15-4-2020
Schaal 1:50
Formaat A3

Maatvoering in mm



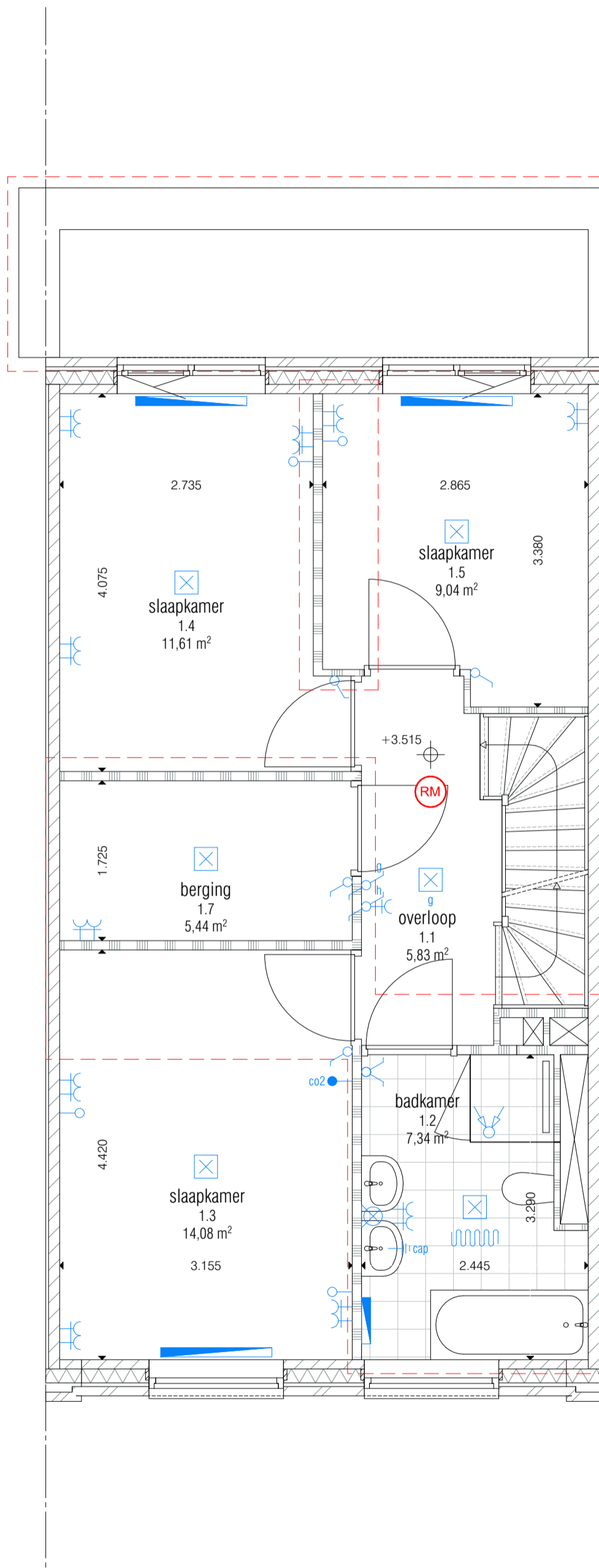

1.010.1.001
optie: uitbouw begane grond 1,8 m

2.040.1.102
optie: verplaatsen tussenwand slaapkamers

2.040.1.114
optie: verplaatsen badkamer
- berging ipv badkamer
- toilet in badkamer
- verplaatsen wand tussen berging en slaapkamer
- verplaatsen binnendeur slaapkamer

Woningtype A

Titel 1e Verdieping
Datum 15-4-2020
Schaal 1:50
Formaat A3

Maatvoering in mm



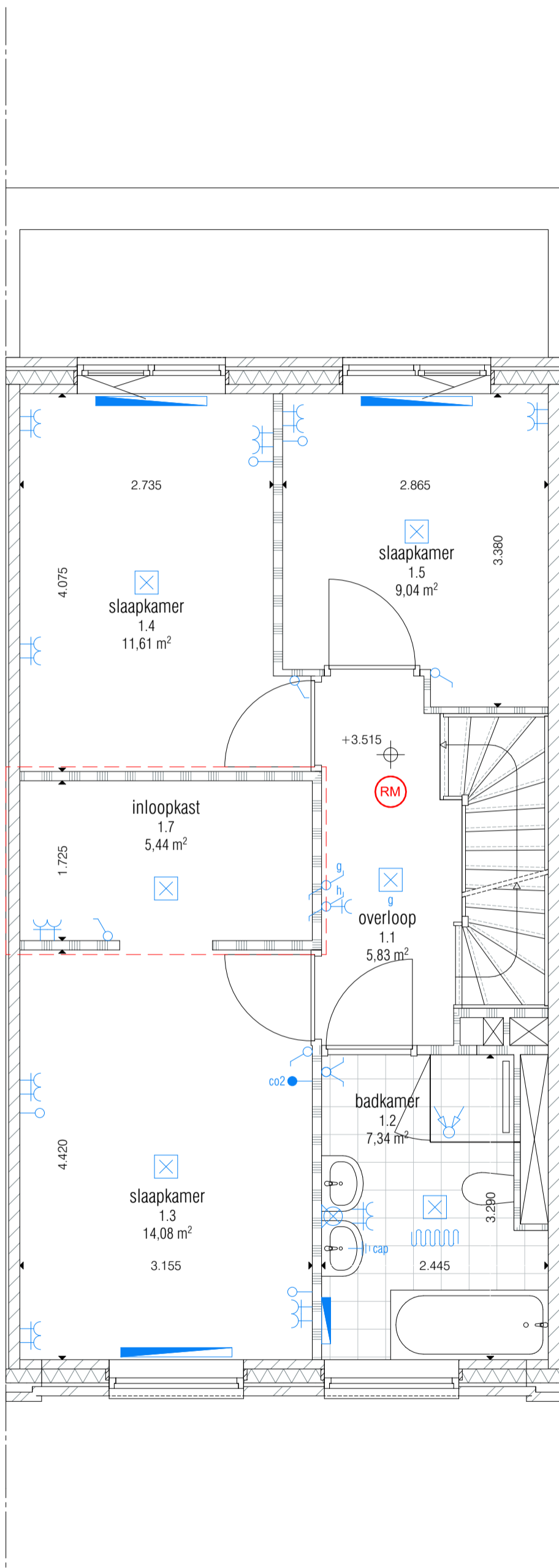

2.040.1.115
 optie: inloopkast ipv berging
 - binnendeur naar overloop vervalt

Woningtype A

Titel 1e Verdieping
 Datum 15-4-2020
 Schaal 1:50
 Formaat A3

Maatvoering in mm

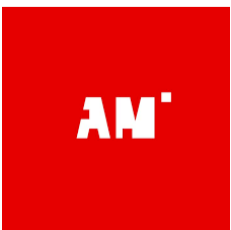

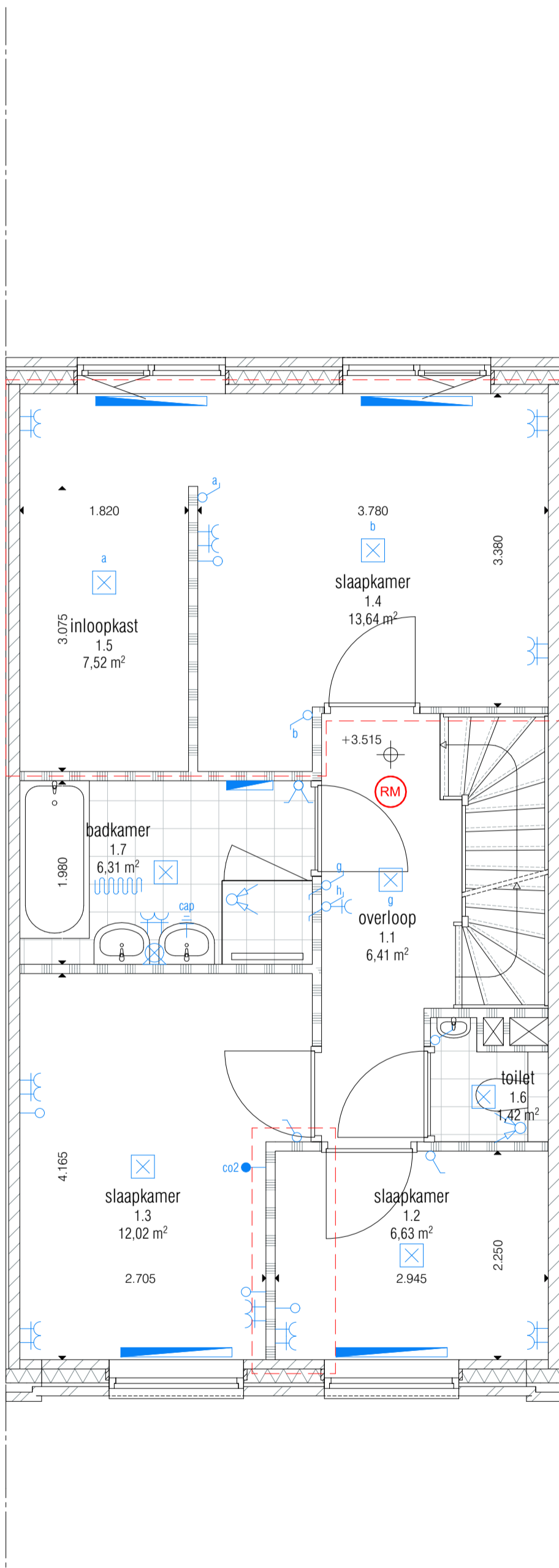

2.040.1.104
 optie: inloopkast ipv slaapkamer 1.5
 - spiegelen binnendeur badkamer

2.040.1.103
 optie: verplaatsen tussenwand slaapkamers

Woningtype A

Titel 1e Verdieping
 Datum 15-4-2020
 Schaal 1:50
 Formaat A3

Maatvoering in mm



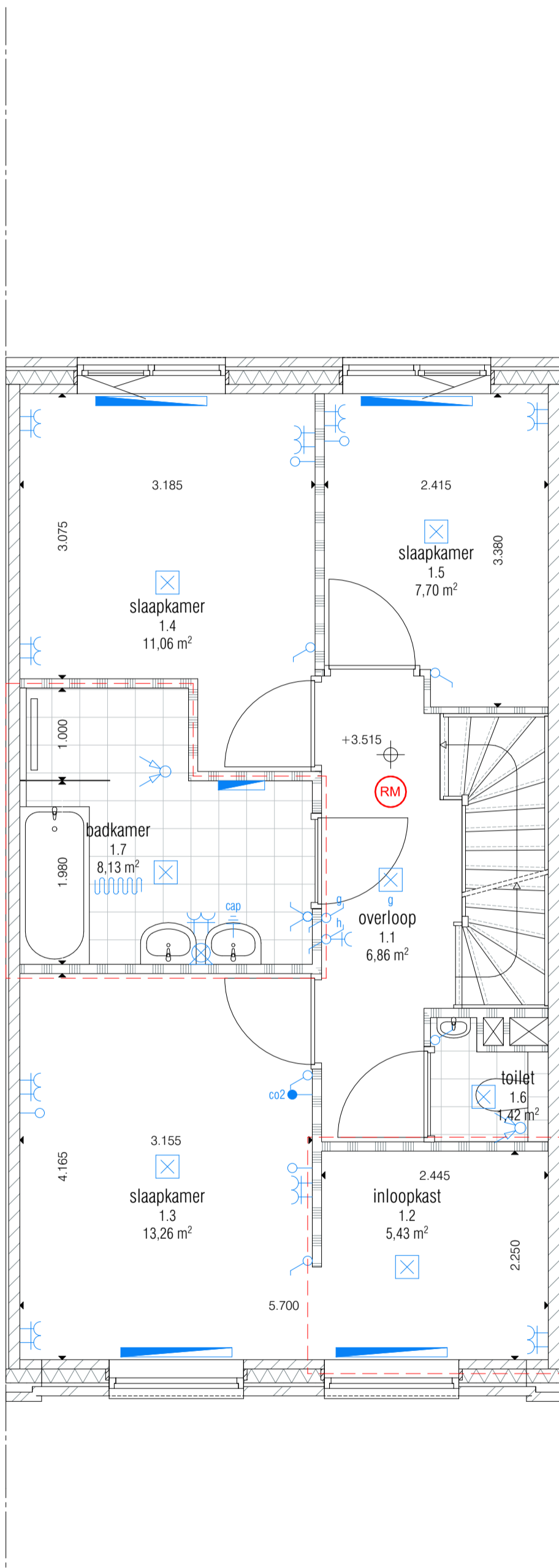

2.040.1.111
 optie: vergroten badkamer
 - verplaatsen douche
 - verplaatsen binnendeur badkamer

2.040.1.107
 optie: inloopkast ipv slaapkamer 1.2

Woningtype A

Titel 1e Verdieping
 Datum 15-4-2020
 Schaal 1:50
 Formaat A3

Maatvoering in mm

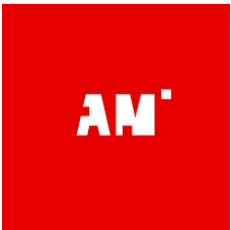

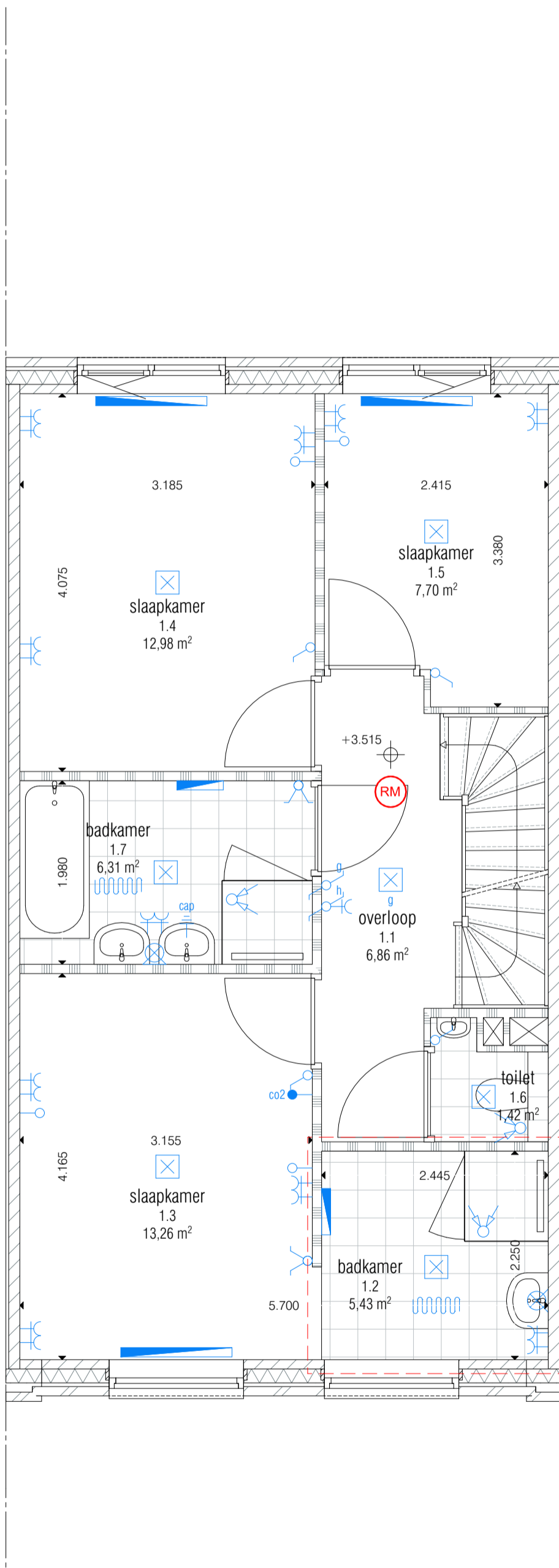

2.040.1.109
 optie: inloopbadkamer ipv slaapkamer 1.2

Woningtype A

Titel 1e Verdieping
 Datum 15-4-2020
 Schaal 1:50
 Formaat A3

Maatvoering in mm



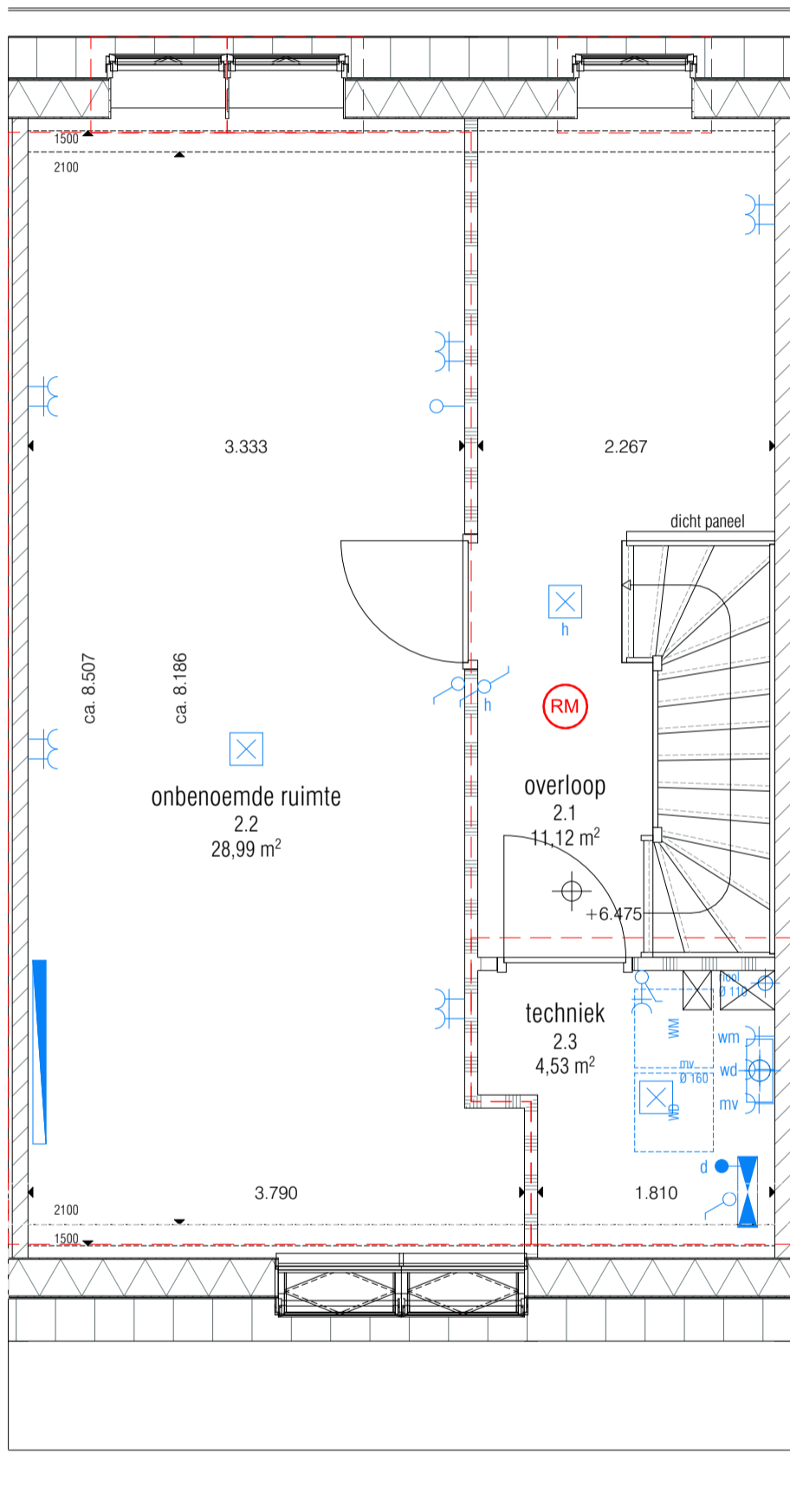

1.030.1.205
optie: enkel dakraam

1.030.1.206
optie: dubbel dakraam

2.040.1.202
optie: zolderindeling met 1 onbenoemde ruimte

2.040.1.212
optie: techniekruimte

Woningtype A

Titel 2e Verdieping
Datum 15-4-2020
Schaal 1:50
Formaat A3

Maatvoering in mm

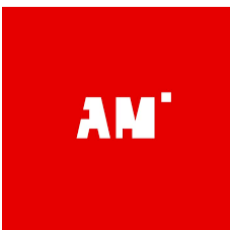

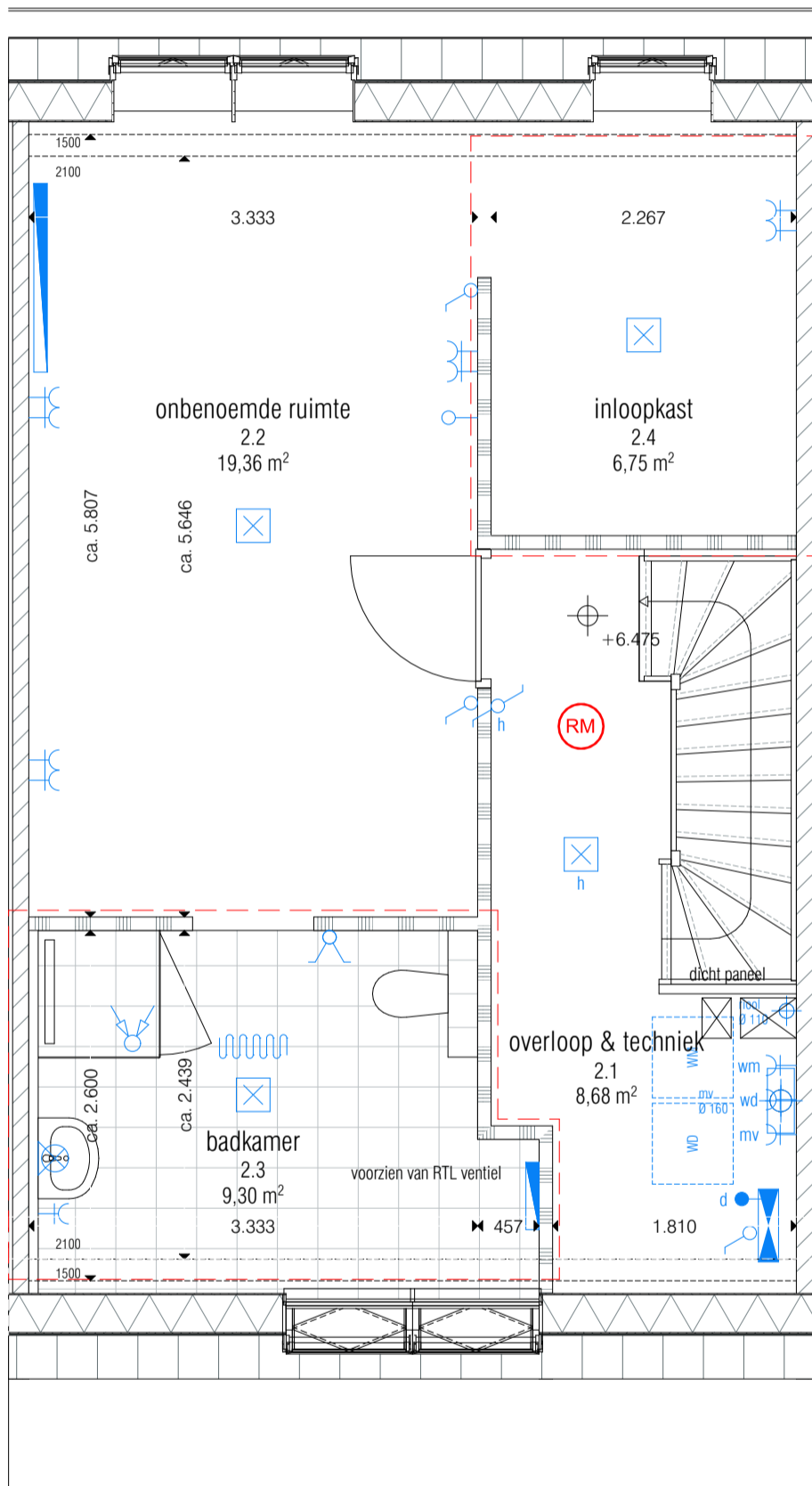

2.040.1.208
optie: inloopkast

2.040.1.211
optie: inloopbadkamer

Woningtype A

Titel 2e Verdieping
Datum 15-4-2020
Schaal 1:50
Formaat A3

Maatvoering in mm



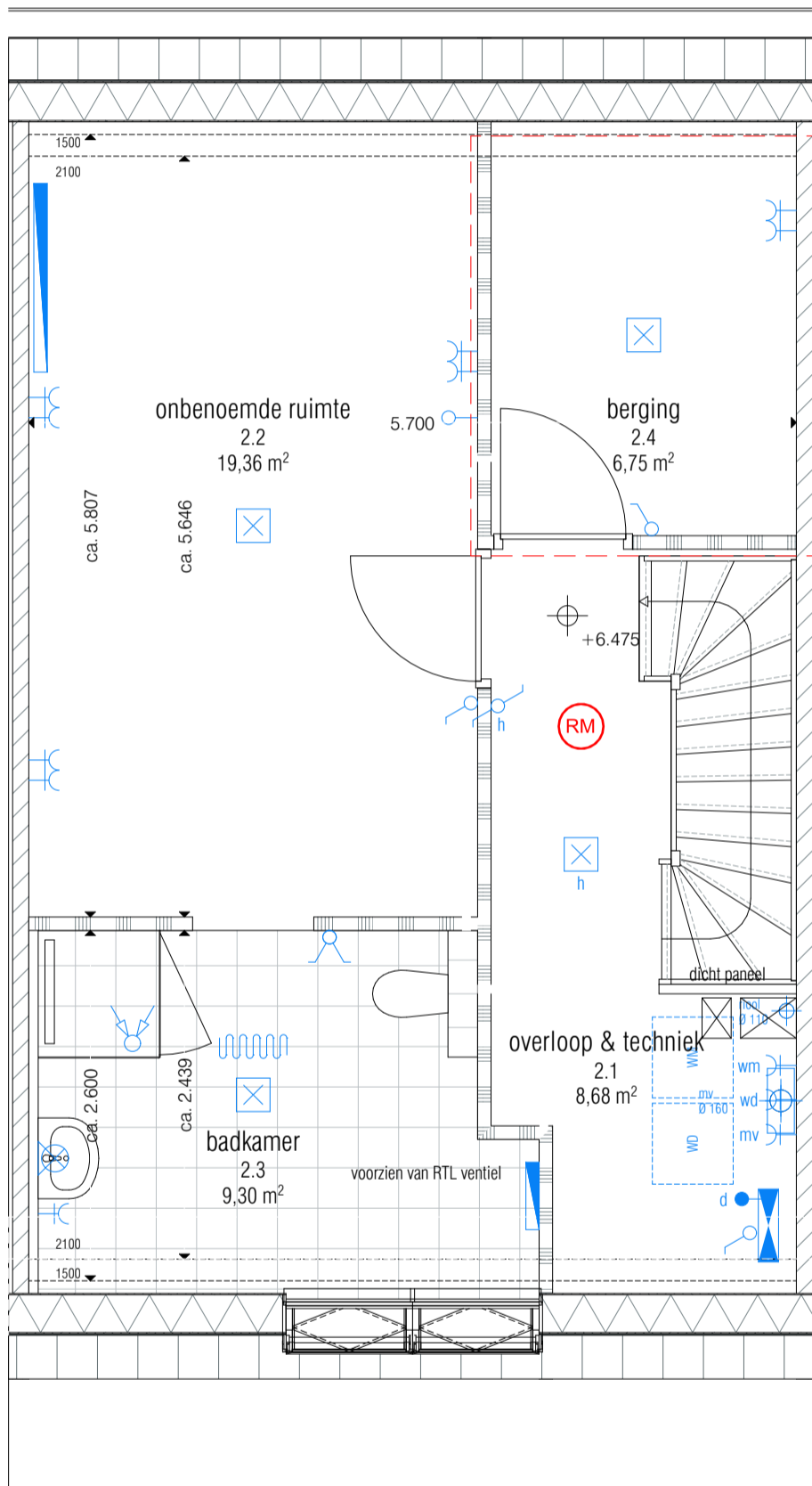

2.040.1.205
optie: berging

Woningtype A

Titel 2e Verdieping
Datum 15-4-2020
Schaal 1:50
Formaat A3

Maatvoering in mm

AM

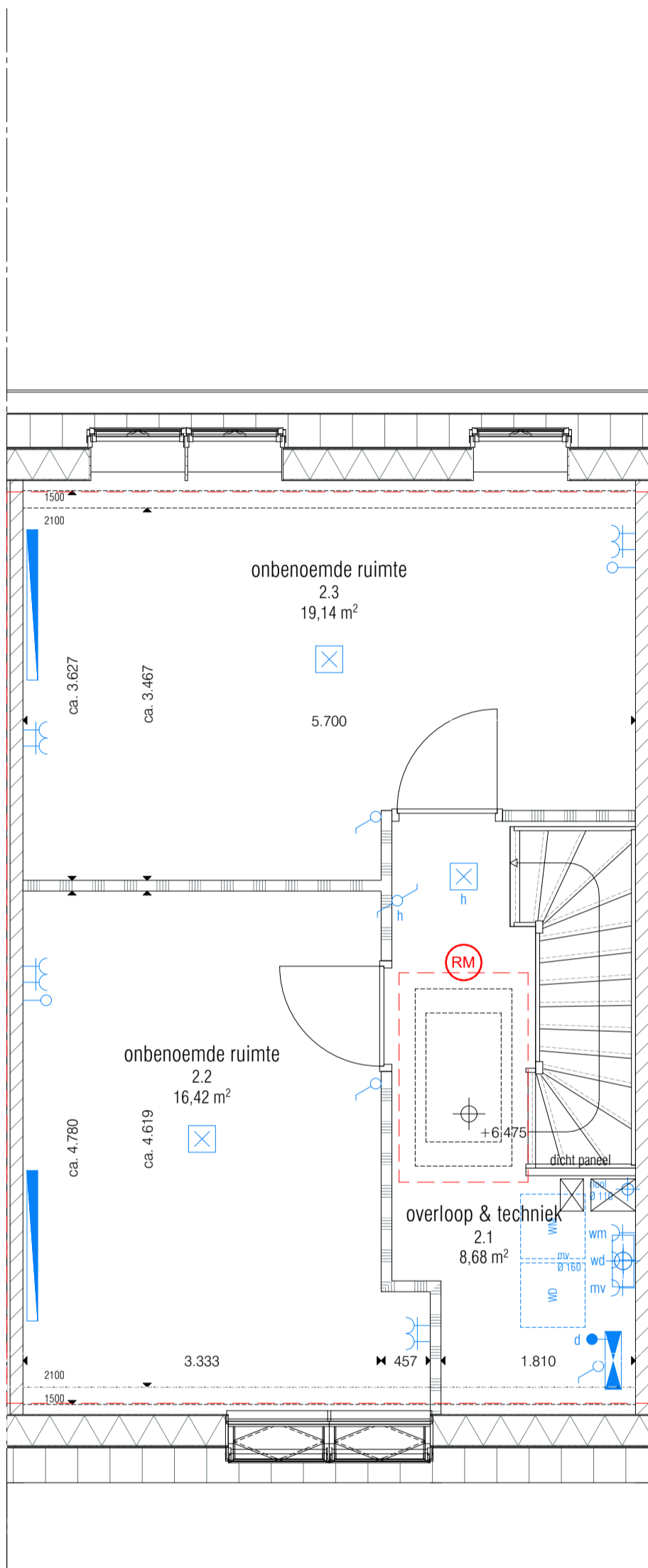

2.040.1.203
optie: zolderindeling met 2 onbenoemde ruimten

2.030.1.202
optie: dakluik

Woningtype A

Titel 2e Verdieping
Datum 15-4-2020
Schaal 1:50
Formaat A3

Maatvoering in mm



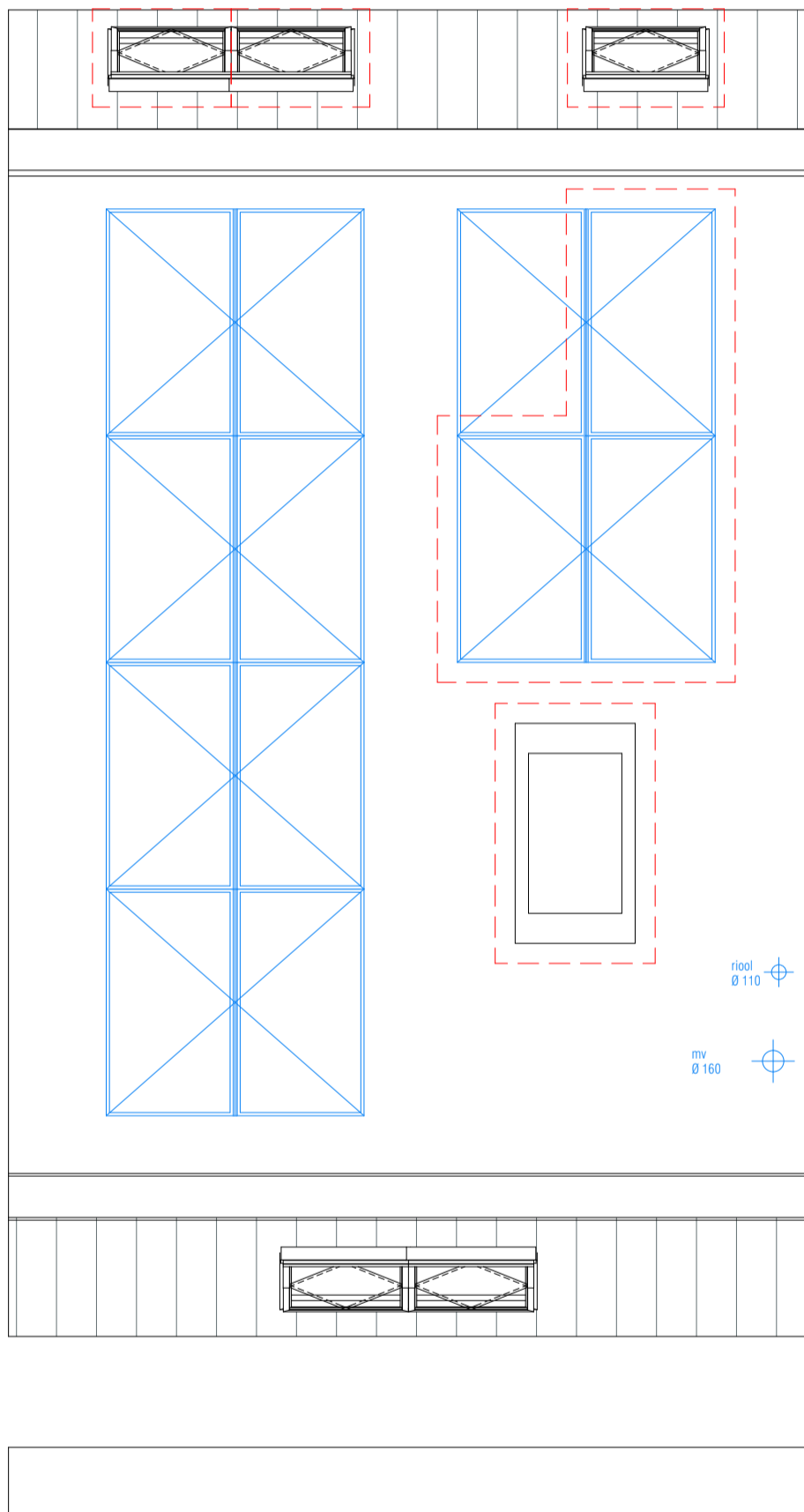

1.030.1.205
optie: enkel dakraam

1.030.1.206
optie: dubbel dakraam

optie: extra PV-panelen

2.030.1.202
optie: dakluik

Woningtype A

Titel Dakaanzicht
Datum 15-4-2020
Schaal 1:50
Formaat A3

Maatvoering in mm



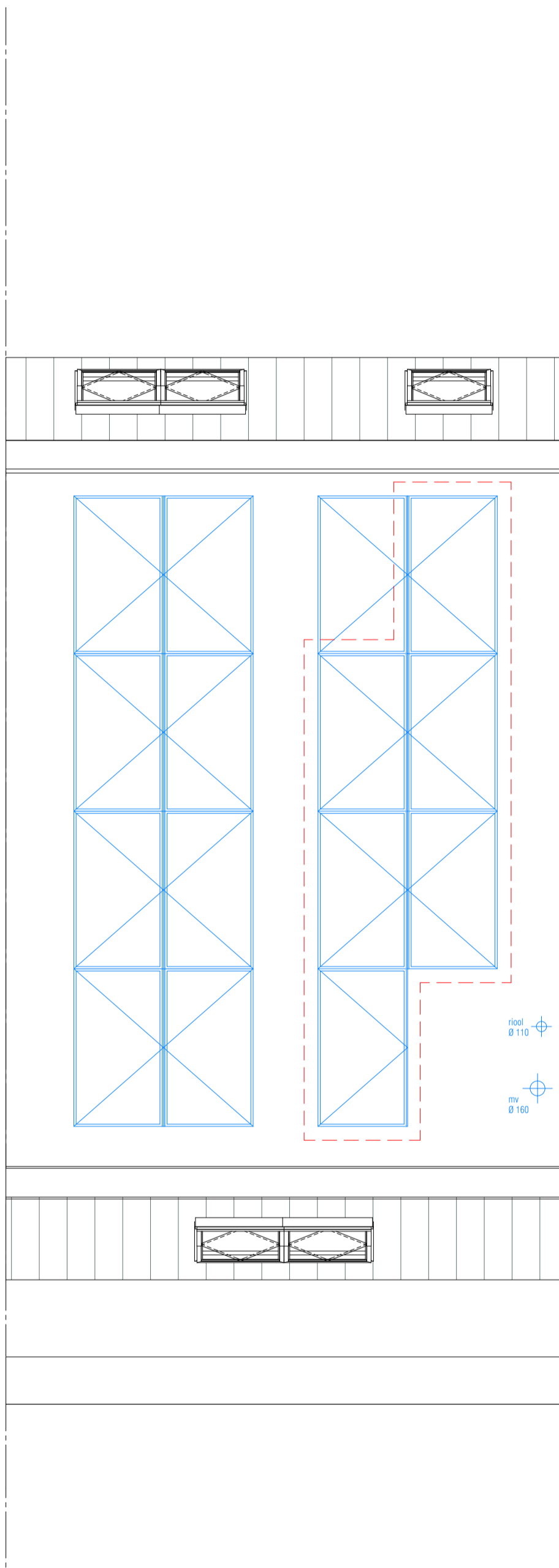

optie: extra PV-panelen

Woningtype A

Titel Dakaanzicht
Datum 15-4-2020
Schaal 1:50
Formaat A3

Maatvoering in mm



Achtergevel

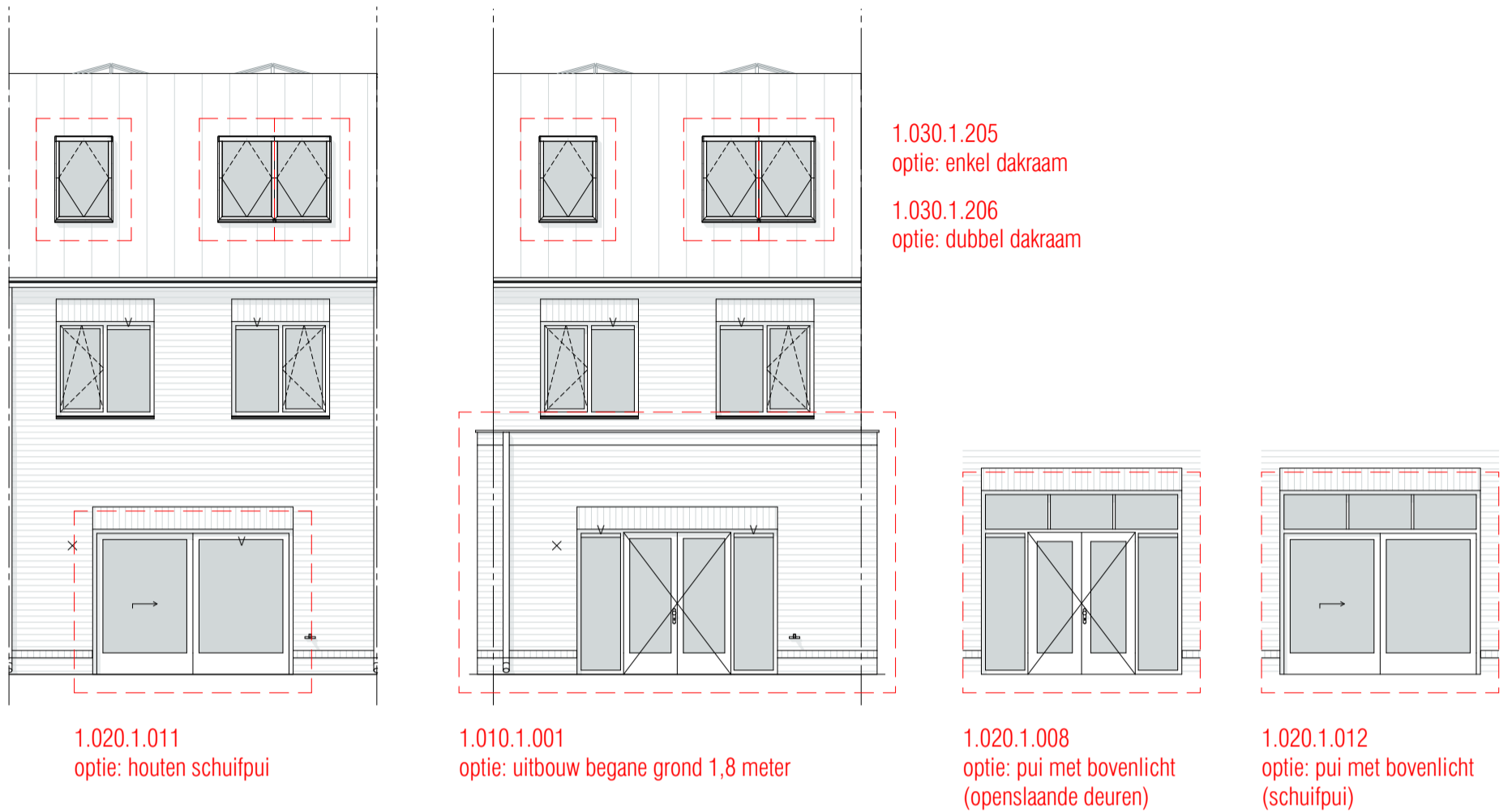

Doorsnede

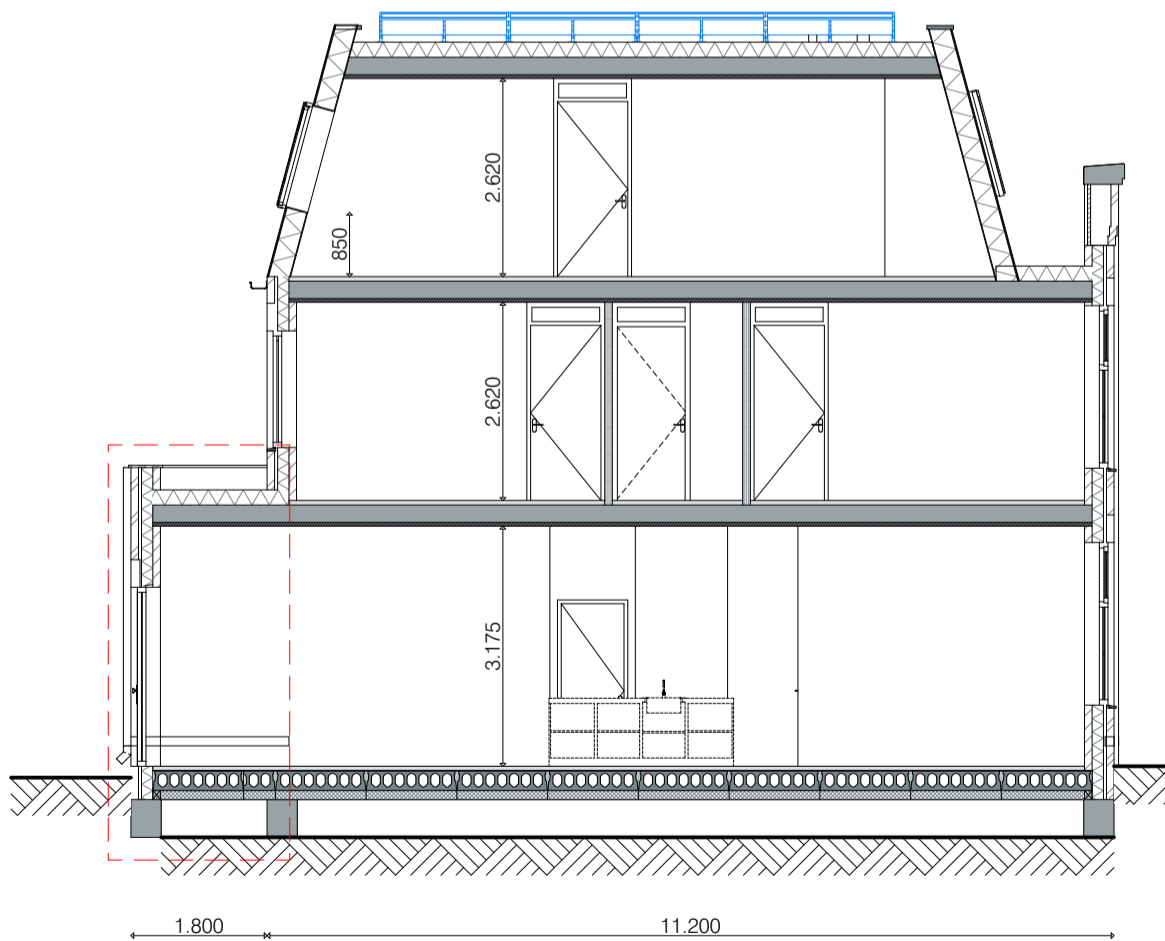

1.010.1.001
optie: uitbouw begane grond 1,8 meter

Woningtype A

Titel Gevels, Doorsnede
Datum 15-4-2020
Schaal 1:100
Formaat A3

Maatvoering in mm

